



SUMMIT[®] 670[™]

56701 US 10/01/10

US ENGLISH

PARTS LIST • LISTE DES PIÈCES • LISTA DE PIEZAS

Catch Pan Holder - 1
Sostenedor del plato recolector - 1
Support de l'égouttoir - 1

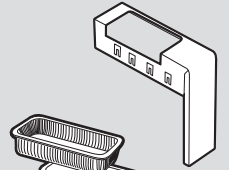

Catch Pan - 1
Plato recolector - 1
Egouttoir - 1



Cooking Grate - 3
Parrilla de cocción - 3
Grille de cuisson - 3

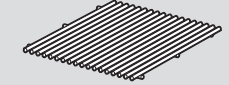

Warming Rack - 1
Rejilla para calentar - 1
Grille de maintien au chaud - 1



Battery Housing - 1
Compartimiento de las baterías - 1
Logement des piles - 1



Rotisserie Fork - 4
Horquilla del asador giratorio - 4
Fourche de la rôtissoire - 4



Rotisserie Spit - 1
Espetón del asador giratorio - 1
Brôche de la rôtissoire - 1



Rotisserie Motor - 1
Motor del asador giratorio - 1
Moteur de la rôtissoire - 1

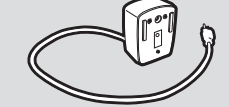

Slide Out Grease Tray - 1
Bandeja de goteo - 1
Plateau de recueil des gouttes - 1

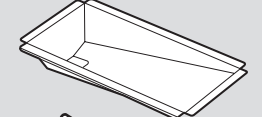

Flavorizer[®] Bar - 12
Barras Flavorizer[®] - 12
Barre Flavorizer[®] - 12



Smoker Bar - 1
Barra del ahumador - 1
Barre du fumeur - 1

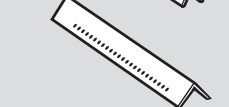

Smoker Box - 1
Caja del ahumador - 1
Boîtier du fumeur - 1

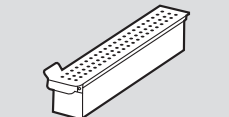

Side Burner Table - 1
Mesa del quemador lateral - 1
Tablette du brûleur latéral - 1

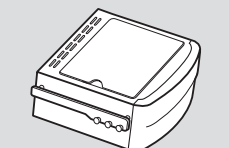

Side Table - 1
Mesa lateral - 1
Tablette latérale - 1

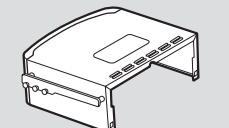

Hardware:
Herrajes:
Matériel:

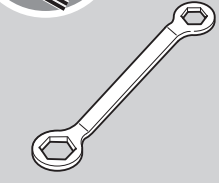

Wrench - 1
Llave - 1
Clé - 1

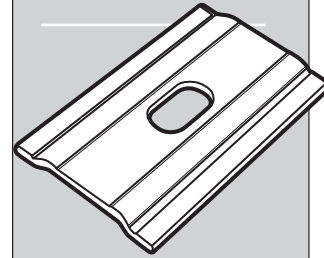

Bracket - 4
Soporte - 4
Support - 4



Silver Hex Bolt
(1/4 - 20 x 5/8 in.) - 4
Perno hexagonal plateado
(1/4 - 20 x 5/8 pulg.) - 4
Boulon hexagonal argenté
(1/4 - 20 x 5/8 po.) - 4



Screw - 3
Tornillo - 3
Vis - 3

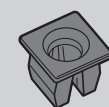

Plastic Plug - 3
Tapón plástico - 3
Bouchon en plastique - 3

ASSEMBLY INSTRUCTIONS • INSTRUCCIONES DE MONTAJE • INSTRUCTIONS DE MONTAGE

3-

TOOLS NEEDED:
HERRAMIENTAS REQUERIDAS:
OUTILS NECESSAIRES:

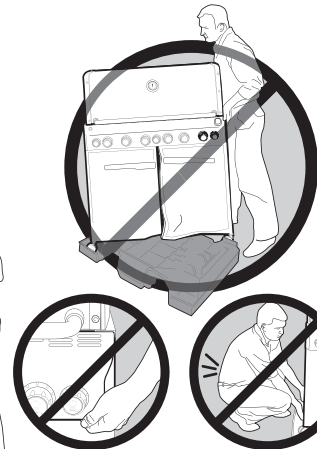
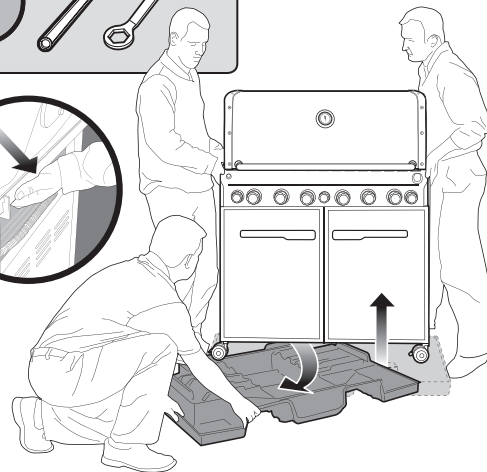
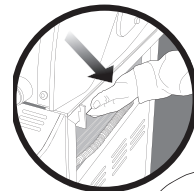

⚠ IMPORTANT: TO PROPERLY ALIGN FRAME AND DOORS, ASSEMBLE GRILL ON A FLAT AND LEVEL SURFACE.

⚠ IMPORTANTE: PARA ALINEAR CORRECTAMENTE EL BASTIDOR Y LAS PUERTAS, ARME LA BARBACOA SOBRE UNA SUPERFICIE PLANA Y HORIZONTAL.

⚠ IMPORTANT: POUR ALIGNER CORRECTEMENT LE CHASSIS ET LES PORTES, ASSEMBLEZ LE GRILL SUR UNE SURFACE PLANE ET A NIVEAU.

- Adjust doors, if necessary
- Si fuese necesario, ajuste la puerta
- Ajustez la porte si nécessaire

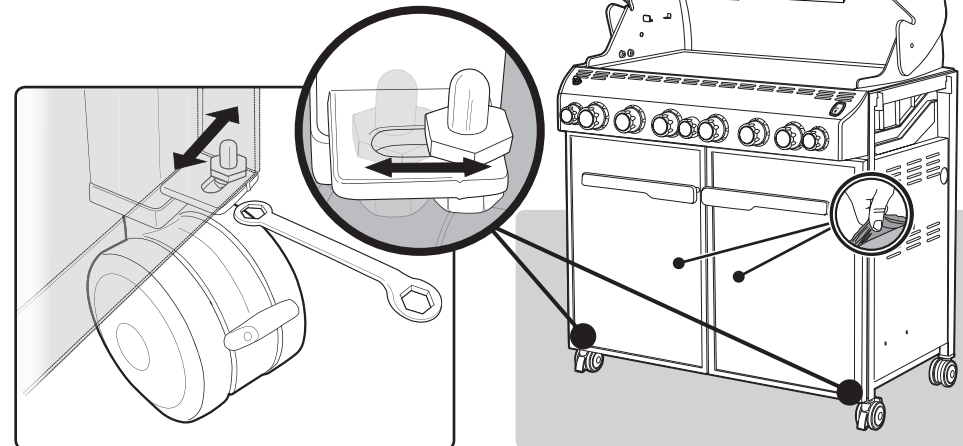

1

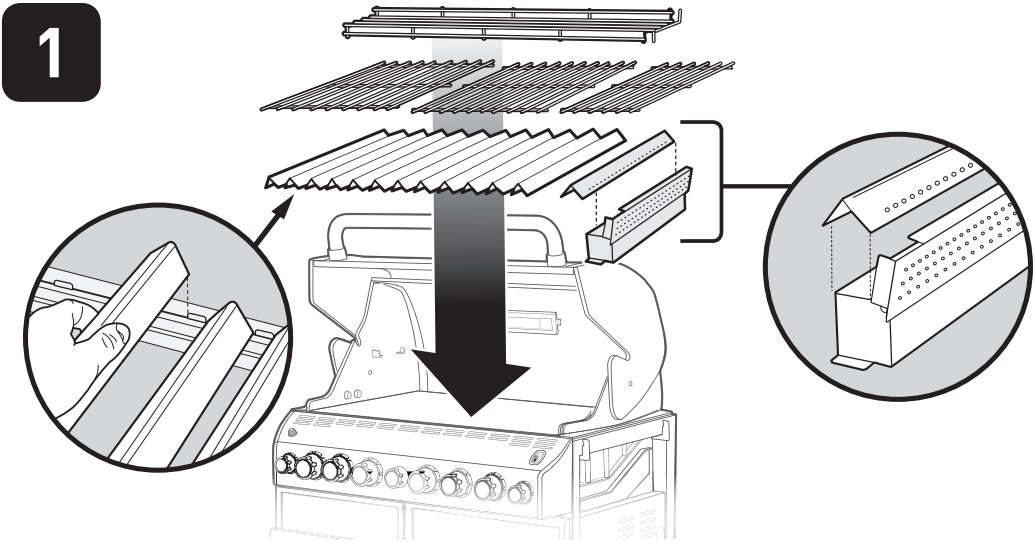

2

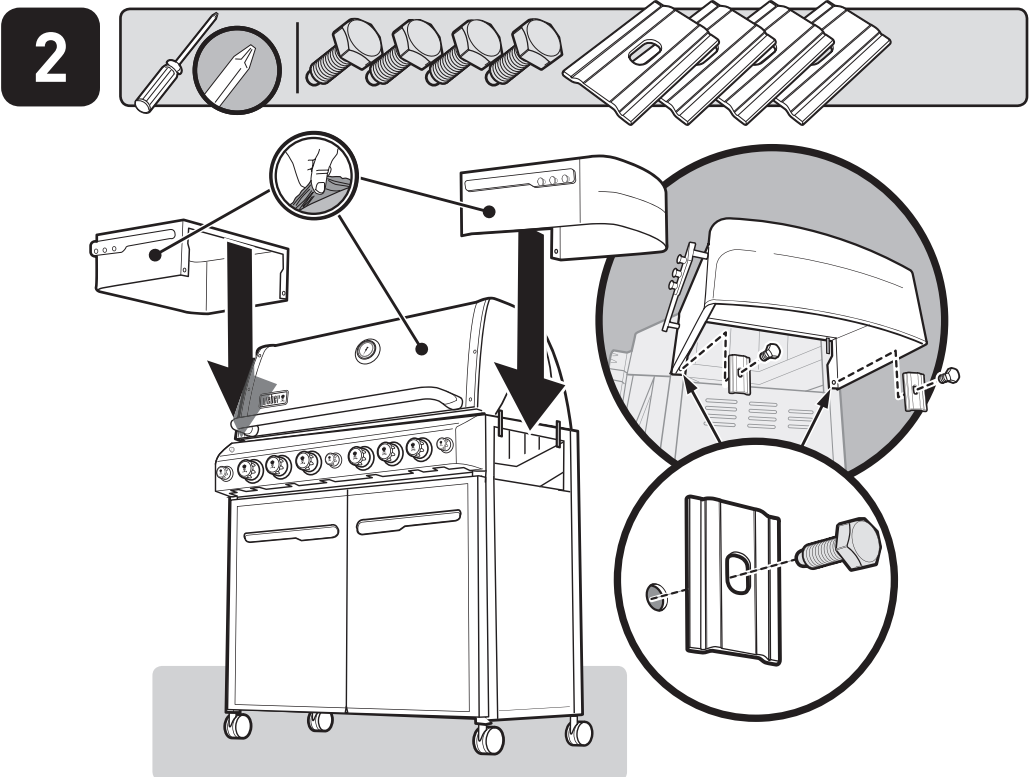

Remove protective film from stainless surface before using grill.

Antes de instalar el componente, retire la película protectora de la pieza de acero inoxidable.

Retirez la pellicule de protection de la surface inoxydable avant d'utiliser le grill.



Hardware:
Herrajes:
Matériel:

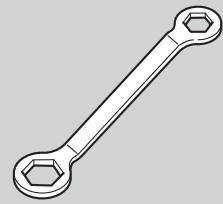

Wrench - 1
Llave - 1
Clé - 1

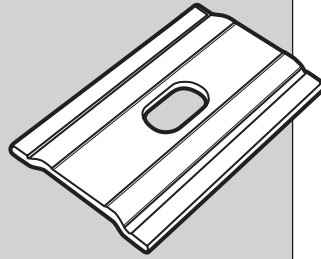

Bracket - 4
Soporte - 4
Support - 4



Silver Hex Bolt
(1/4 - 20 x 5/8 In.) - 4
Perno hexagonal plateado
(1/4 - 20 x 5/8 pulg.) - 4
Boulon hexagonal argenté
(1/4 - 20 x 5/8 po.) - 4



Screw - 3
Tornillo - 3
Vis - 3

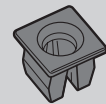

Plastic Plug - 3
Tapón plástico - 3
Bouchon en plastique - 3

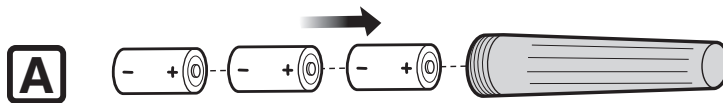
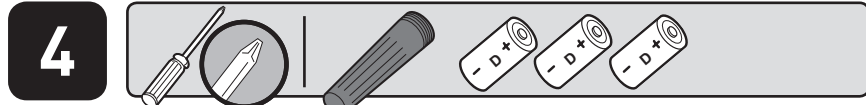
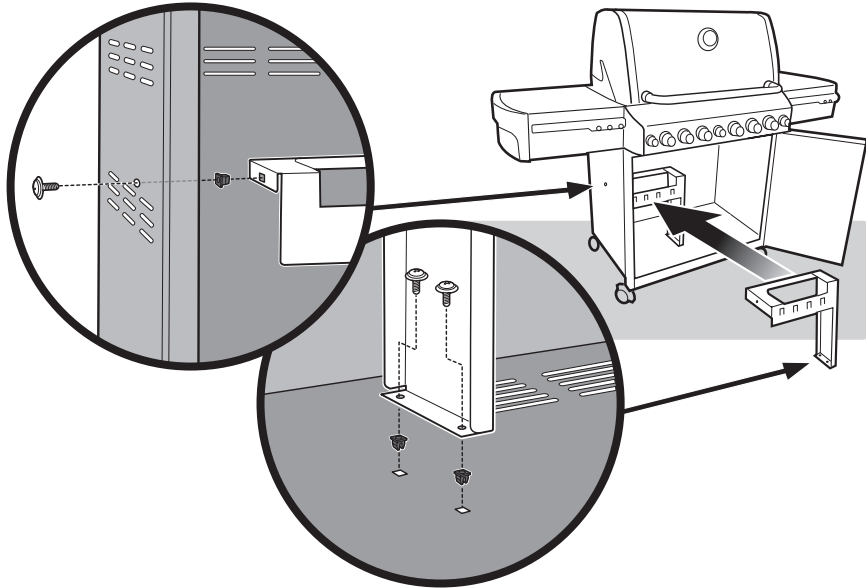
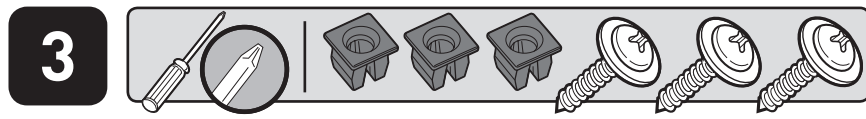

Requires 3 "D" alkaline batteries (Included). Use alkaline batteries only. Do not mix old and new batteries or different types of batteries (standard, alkaline or rechargeable).

Requiere 3 baterías alcalinas "D" (incluidas). Use solamente baterías alcalinas. No mezcle baterías nuevas con viejas o diferentes tipos de baterías entre sí (normales, alcalinas o recargables).

Fonctionne avec 3 piles alcalines "D" (Fournies). Utilisez des piles alcalines uniquement. Ne mélangez pas des piles usagées et des piles neuves ou différents types de piles (ordinaires, alcalines ou rechargeables).

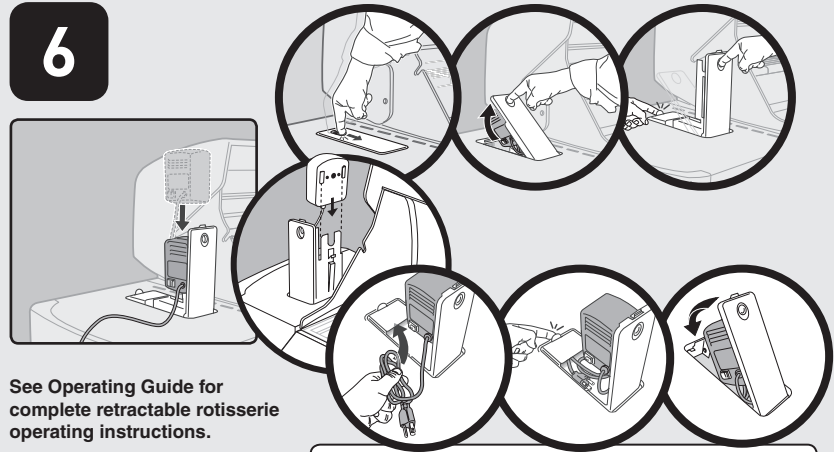
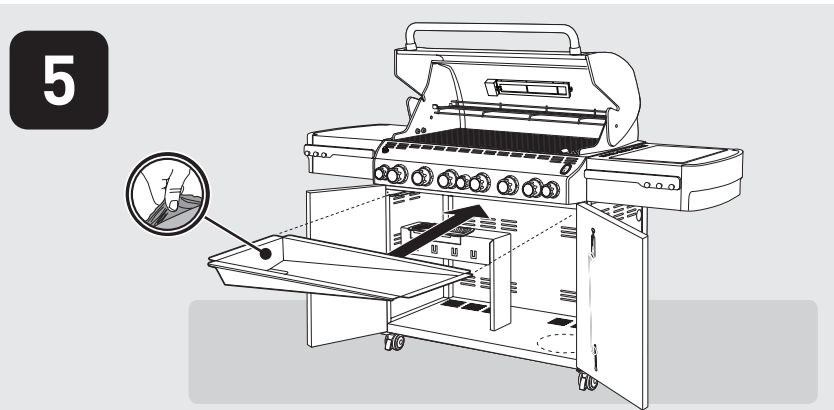
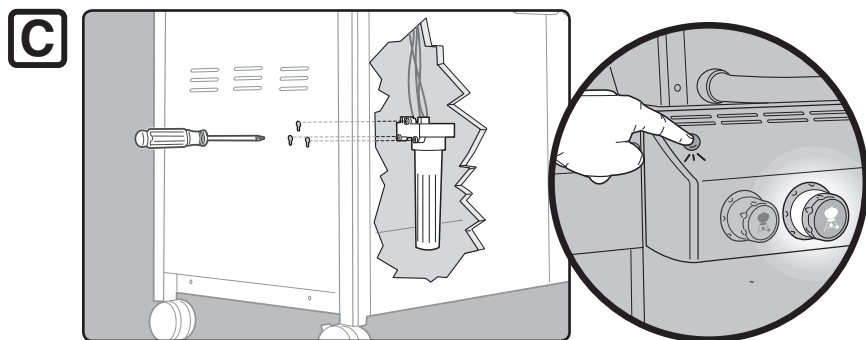
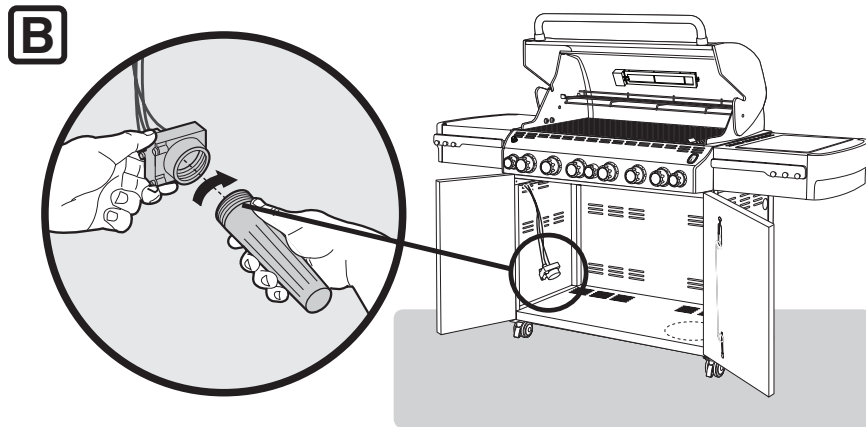

See Operating Guide for complete retractable rotisserie operating instructions.

Consulte la Guía del Propietario para las instrucciones completas acerca del asador giratorio retráctil.

Voir le Mode d'emploi pour des instructions complètes concernant l'utilisation de la rôtissoire rétractable.

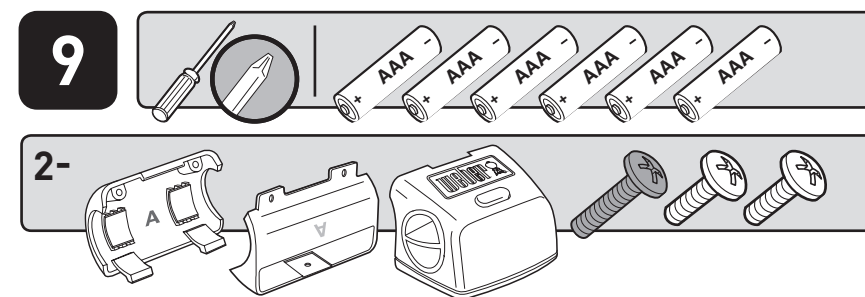
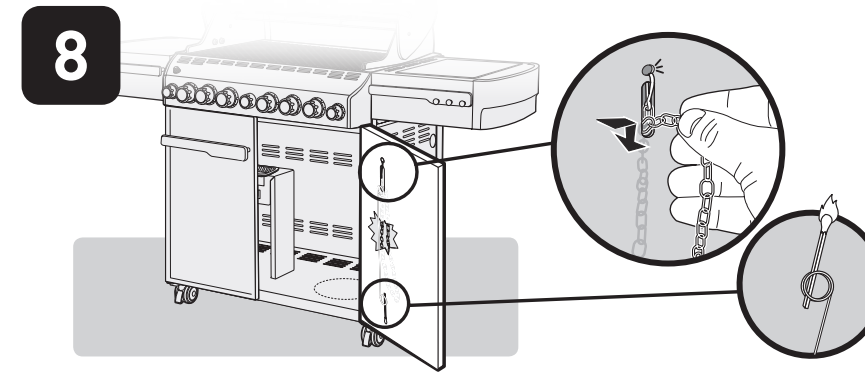
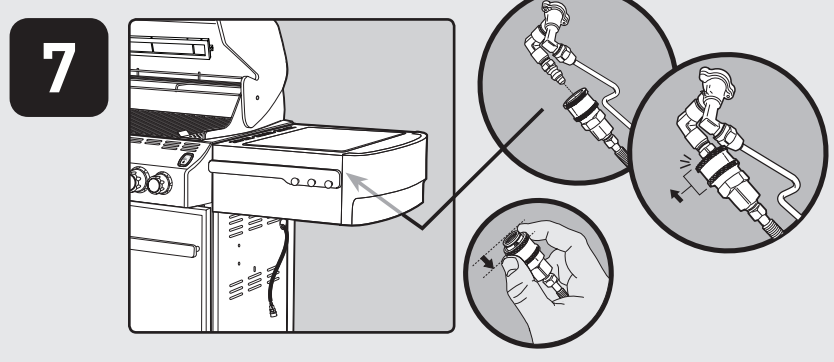
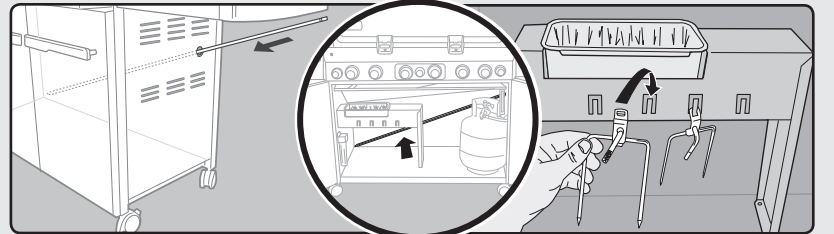
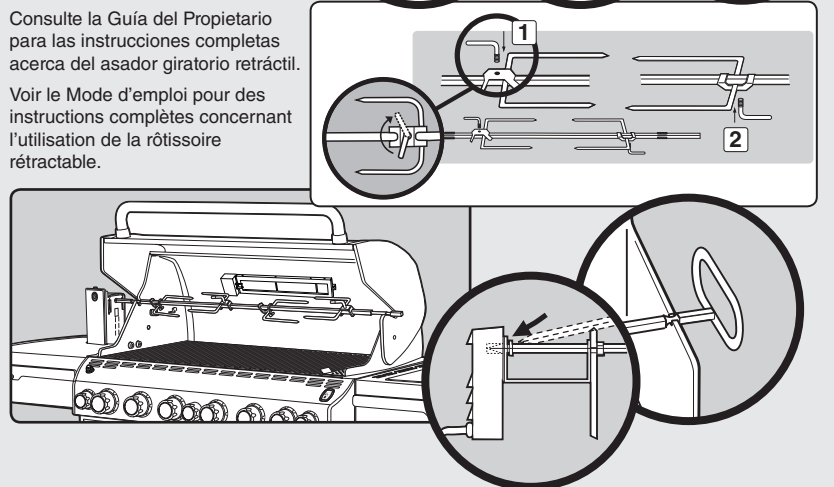

The Weber Grill Out™ Handle Light has a "Tilt Sensor": Lid up - ON / Lid Closed - OFF. The power button (a) activates or deactivates the "Tilt Sensor." For daytime use, deactivate the sensor by pressing power button (a).

La Lámpara de Asa Weber Grill Out™ tiene un "sensor de inclinación": tapa abierta - ENCENDIDA / tapa cerrada - APAGADA. El botón de encendido (a) activa o desactiva al "sensor de inclinación". Para uso durante el día, desactive al sensor pulsando el botón de encendido (a).

La Lampe de poignée Weber Grill Out™ est pourvu d'un "Décteur Tilt" : Couvercle relevé - MARCHÉ / Couvercle fermé - ARRET (OFF). Le bouton d'alimentation électrique (a) active ou désactive le "Décteur Tilt." Pour une utilisation pendant la journée, veuillez désactiver le détecteur en appuyant sur le bouton d'alimentation électrique (a).

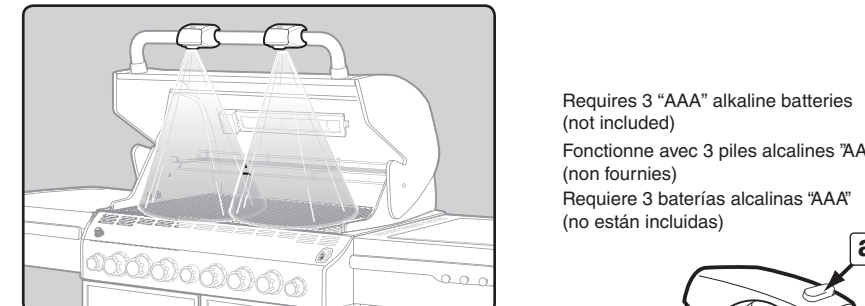

Requires 3 "AAA" alkaline batteries (not included)
Fonctionne avec 3 piles alcalines "AAA" (non fournies)
Requiere 3 baterías alcalinas "AAA" (no están incluidas)

