

ClubMan

Assembly and Operating Instructions

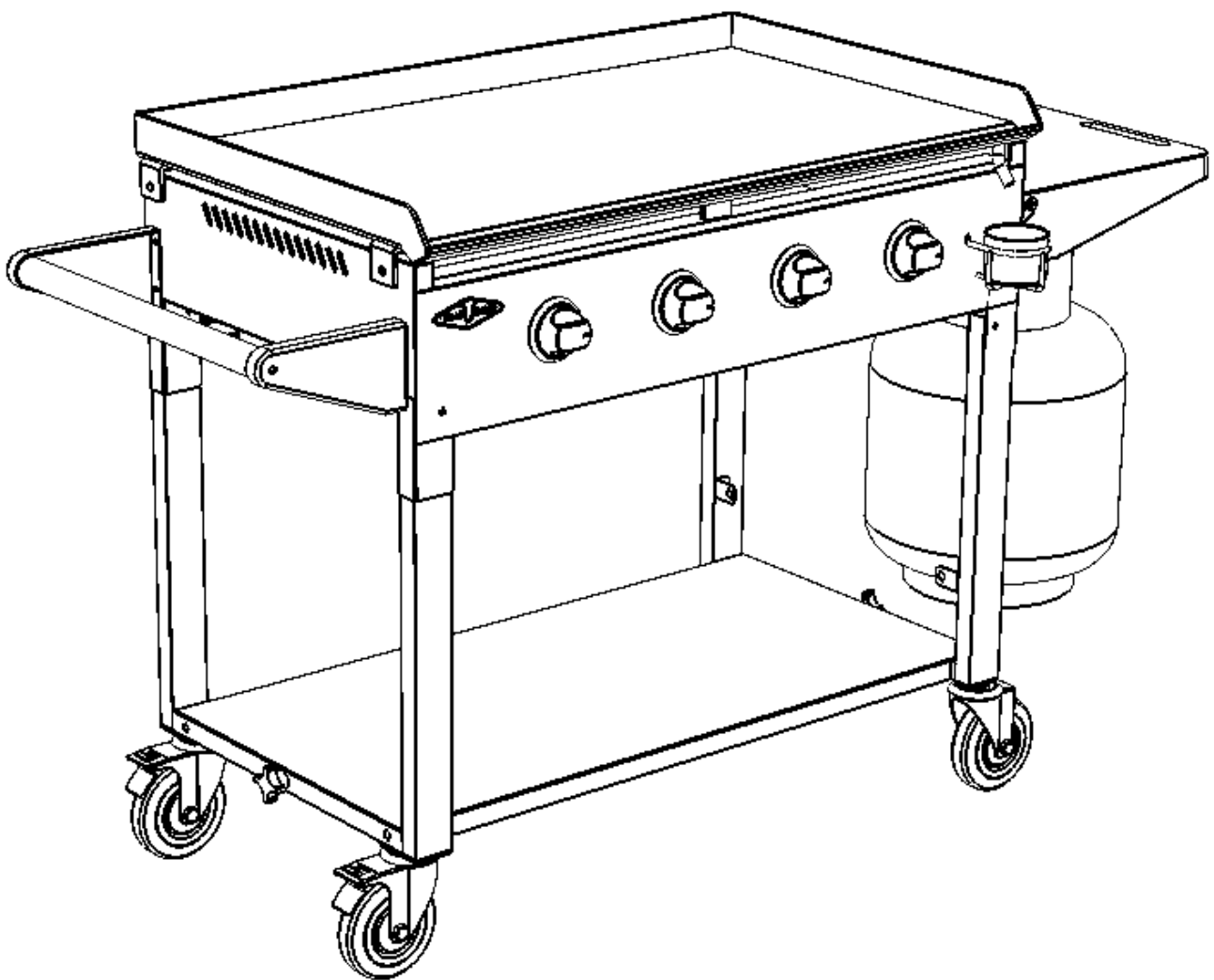

For Models:

16440

16540

16640

FOR OUTDOORS USE ONLY





Serious Barbecues

IMPORTANT:

- BeefEater Barbecues are approved for **OUTDOOR USE ONLY** and must not be used in a building, garage or any other enclosed area.
- BeefEater Barbecues must not be used inside recreational vehicles or boats.
- Read instructions thoroughly before operating this Barbecue.
- Save this manual for future reference.
- Always use the Barbecue on a flat, level surface.
- Some foods produce flammable fats and juices. Regular cleaning is essential.
- Attend an operating barbecue at all times. Damage caused by fat & grease fires is not covered by warranty.
- When not in use keep Barbecue dry and covered.

FOR YOUR SAFETY

If you smell gas:

1. Shut off gas to the appliance.
2. Extinguish any open flame.
3. Open lid.
4. If odour continues, immediately call your gas supplier or your fire department.

FOR YOUR SAFETY

1. Do not store or use gasoline or other flammable vapours or liquids in the vicinity of this or any other appliance.
2. An LPG cylinder not connected for use shall not be stored in the vicinity of this or any other appliance.

Safety Warning



Failure to follow these instructions and observe the warnings provided in this operations manual could result in fire, explosion or burn hazard, which could cause property damage, personal injury or death.

Gas vapour is highly explosive and can cause serious bodily injury or damage to property if allowed to accumulate in a confined space and ignited.

This appliance must not be installed under or on any combustible material. Minimum clearance from combustible materials to all sides of the appliance is 450mm (18”).

These instructions must be left with the owner.

NOTES:

1. Do not use gas other than the type specified on the Data Plate
2. The appliance is designed for use by adults, keep children away from the ClubMan at all times.
3. Use only on a flat, level, stable non-combustible surface. Do not use this appliance on any surface that can burn or melt.
4. When in use, gas cylinder should be kept away from ClubMan, and supply hose kept away from any hot surfaces.
5. To prevent accidental fires, before using the appliance ensure that there is no apparent damage to hose and regulator and all joint connections are in good order and not leaking.
6. Before every use of the appliance, use a soapy water solution on all joints in order to check for leaks. If bubbles appear, it indicates that there is a leak and the appliance must not be used.
7. LPG cylinder, regulator and hose must comply with national standards.
8. Do not move or attempt to move the appliance while in operation.
9. Do not operate this appliance before leak checking hoses and gas cylinder connection.

To the installer:

- For fixed installations, refer also to the requirements of AS5601/AG601, local authority, gas, electricity, and any other relevant statutory regulations.
- For fix installations, refer to AS 5601/AG 601 for pipe sizing details.
- Consult other trades. Where required, consult a bricklayer or an electrician for parts of the installation that could have an effect on these areas.
- Allow a 20mm gap from back of barbecue body for ventilation and air access.
- Test appliance for correct operation before leaving, and instruct user on its use.
- If correct operation can not be achieved, disconnect barbecue from gas supply, and contact your nearest BeefEater dealer.
- Please only use BeefEater supplied hose(s) to connect this appliance. Natural Gas conversion kits are available from your nearest BeefEater dealer.

Leave these instructions with customer



Serious Barbecues

DO NOT

- Lean over barbecue when lighting.
- Leave cooking food unattended.
- Delay lighting burners after turning gas on.
- Spray or store aerosols in vicinity of barbecue whilst in operation.
- Store combustible materials, gasoline or flammable liquids or vapours within 450mm (18") of barbecue.
- Use caustic based cleaning agents on the barbecue.
- Operate barbecue with any cover on.
- Use plastic or glass utensils on the barbecue.
- Operate barbecue in strong winds.
- Attempt to dismantle control valves.
- Attempt to dismantle or adjust regulator.
- Test for gas leaks with a naked flame.
- Store gas cylinder indoors, or in any enclosed area.
- Lay the gas cylinder down. Always keep it upright.
- Use barbecue indoors.
- Expose hose to direct sunlight.
- Modify the construction of this appliance or the size of any burner or valve orifice.
- Move the appliance during use.
- Obstruct any ventilation of barbecue or the cylinder.
- Allow the flexible gas supply hose or any electrical cord to come in contact with hot surface of the appliance.
- Allow children to operate this appliance.
- Use charcoal or any other solid fuel in this appliance.
- Disconnect any gas fittings while the appliance is operating.
- Use a rusty or dented gas cylinder or cylinder with a damaged gas valve.
- Fill the gas cylinder beyond 80% capacity.
- Touch some accessible parts, other than the ones meant for handling. They may be hot.

DO

- Spanner tighten all gas fittings as per instructions.
- Check all gas hoses and line connections for damage, cuts or cracks each time the appliance is about to be used.
- Always leak test with a solution of soapy water.
- Check main opening, throat and venturi to each burner and pilot flame tube regularly for insect nests (eg. wasp, ants or spiders). Nests are dangerous and must be cleaned out thoroughly.
- Visually check burner flames to confirm lighting.
- Use your barbecue only on a level surface.
- Attend barbecue whilst cooking food.
- Preheat the barbecue for up to 10 minutes.
- After cooking turn barbecue to high for up to 10 minutes to burn off excess grease.
- Let the barbecue cool before replacing any lid or cover.
- Regularly replace foil material in grease/drip tray.
- Keep children away from barbecue at all times.
- Have the gas cylinder filled by an authorised LPG supplier.
- Refer to this instruction manual if in doubt concerning assembly, installation, or operation.
- Use protective gloves when handling hot components.
- Close the gas cylinder valve after each use.
- Clean the grease/drip tray regularly and clean the appliance at least twice annually.
- Always remove any lid or cover off the appliance before lighting.
- Carefully follow the instructions relating to the hose/regulator connection.
- Keep the barbecue area free from combustible materials, gasoline, flammable liquids or vapours.

- Should the appliance go out for any reason, turn off all control knobs and the cylinder gas valve. Wait 5 minutes before attempting to relight the appliance.
- If a grease or fat fire should occur, immediately turn off all control knobs and the gas cylinder valve until the fire is out. Remove all food from the appliance.
- A leak test must be carried out prior to using the appliance for the first time and whenever the gas cylinder is refilled or whenever the gas hose and regulator have been disconnected from the gas cylinder or appliance.



Serious Barbecues

Gas Cylinder Safety Information

- Gas cylinders **must be stored outdoors**, out of reach of children and must not be stored in a building, garage or any other enclosed area.
- This appliance is designed to be used with a gas cylinder not exceeding 9KG (20lbs) capacity.
- The Gas cylinder must be constructed and marked in accordance with specifications for LP Gas Cylinders.
- The gas cylinder supply valve must be turned off when the appliance is not in use.
- The gas cylinder used must incorporate a safety collar to protect the valve assembly.
- The gas cylinder must always be kept and used in the upright position.
- Gas cylinder must be positioned on the dedicated cylinder hook when in use.

Important:

When disconnecting and removing the gas cylinder for the purpose of refilling, always observe the following procedure:

- Ensure that all gas control valves on the appliance and the gas cylinder are turned off before disconnecting the gas line from the cylinder.
- Do not smoke or use a naked flame near the appliance or gas cylinder while disconnecting the gas line between the appliance and gas cylinder.
- Remove the gas cylinder from the enclosure before disconnecting the gas line from the appliance.
- Tighten all connections before placing the gas cylinder back in its enclosure.

The Gas Leak Testing Procedure should be conducted every time the gas cylinder is refilled and reconnected to the appliance – before using the appliance.

Regulator Connection

1. Check that all control knobs are in the 'Off' position.
2. Make sure the cylinder valve is off by turning the valve knob all the way clockwise.
3. Remove the protective cap from the cylinder if present.
4. Make connection as described in figures 1 and 2.
5. Leak-test the connection with a soapy water solution. (See Gas Leak Testing Procedure).

Hose and regulator replacement must be a genuine part specified for this appliance and is obtainable from your nearest BeefEater stockist.

Fig 1

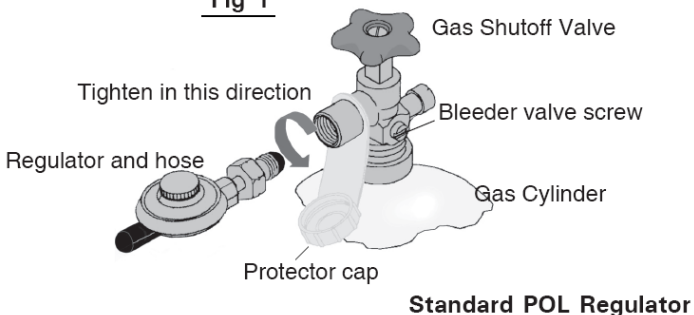
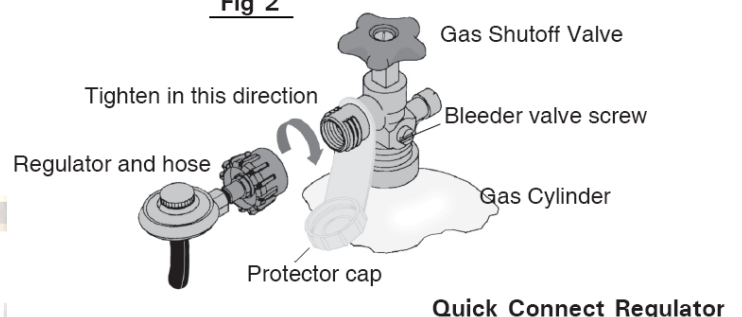

Fig 2





Serious Barbecues

Gas Leak Test Procedure

Use the following procedure to check for gas leaks.
Never use a naked flame to check for gas leaks.

1. In a small container, mix up a solution of water and detergent or soap. Mix the solution well.
2. Make sure that the gas supply valve on the gas cylinder is turned on.
3. Make sure that the gas control valves on the appliance are all turned off.
4. Using a brush or spray bottle apply the solution to the gas line and each join in the gas line. See Fig 3.
5. Bubbling of the solution will indicate that there is a leak present.
6. Re-tighten or re-seal any joints that are leaking.
7. If a leak persists then contact your distributor or the manufacturer for assistance.

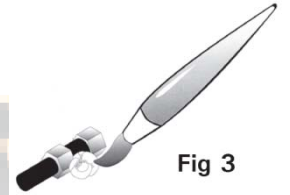
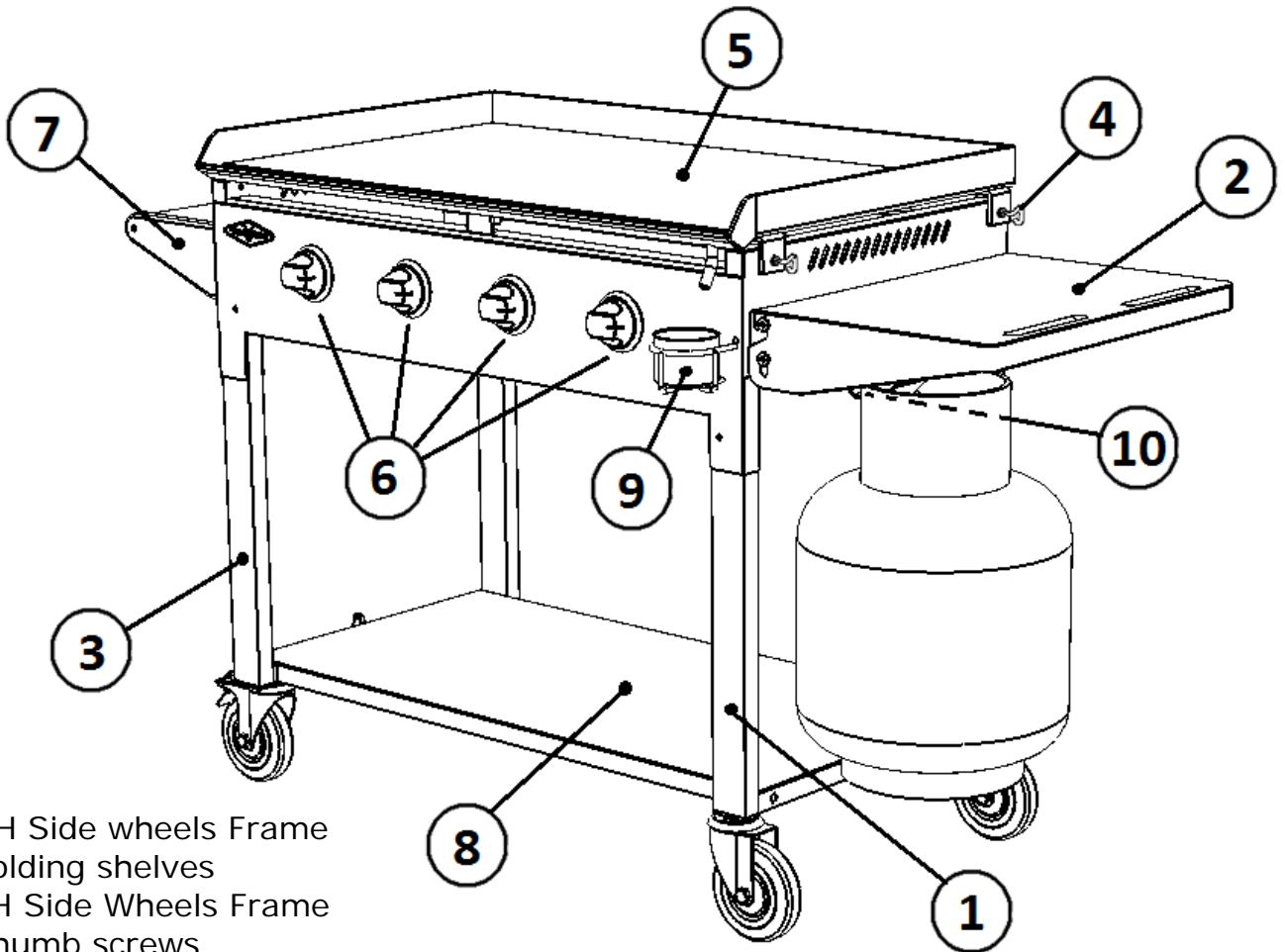

Fig 3

Know your ClubMan BBO:



1. RH Side wheels Frame
2. Folding shelves
3. LH Side Wheels Frame
4. Thumb screws
5. Cooking Plate
6. Operating Knobs
7. Handle
8. Bottom Shelf or Cross Brace
9. Fat Collecting Cup
10. Cylinder Hook (under RH shelf)



Serious Barbecues

Installation Instructions

The legs are folded on the underside of the BBQ. To unfold:

1. Place the BBQ upside down, and release legs by unscrewing the 2 Hand Screws.

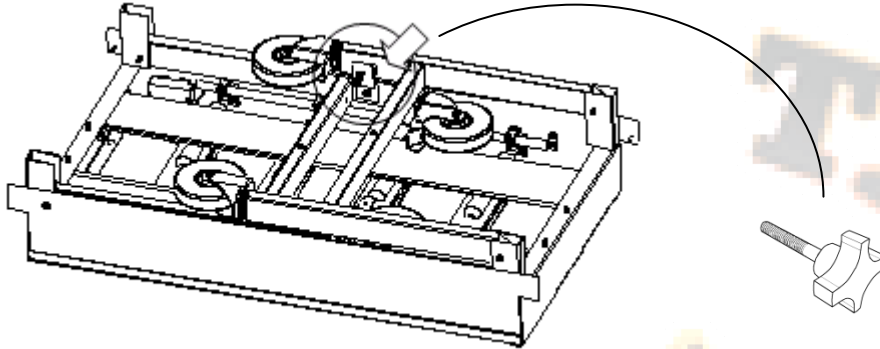

2. Pull both Wheels Frames to a vertical position. Place the bottom shelf (or cross-brace) in between the horizontal members, and tighten with a hand-screw on each side.

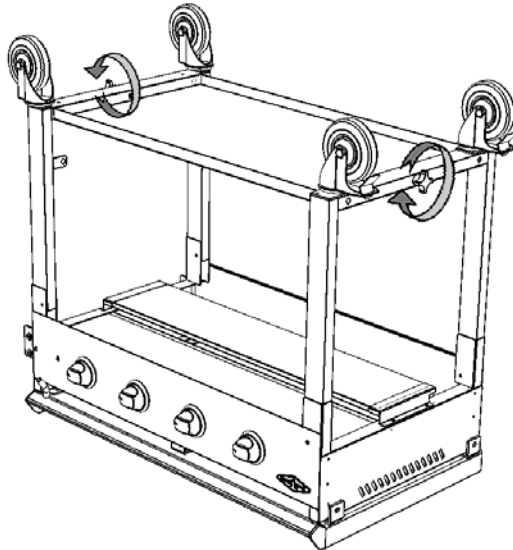

3. Turn back the right way, and install the fat collecting cup holder. Place cup inside.

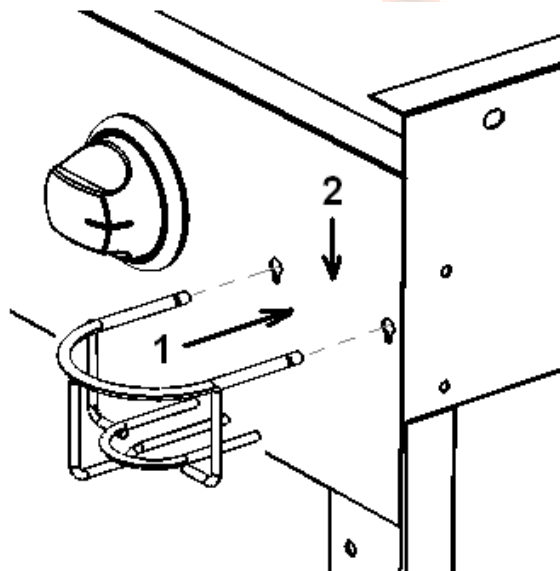



Beef Eater
Beef Eater
Serious Barbecues

4. Install the shelf on the right hand side:

The shelf should be installed such that the bottom screw in each bracket will go through the hole in the shelf. The top remain free, so the shelf can be folded.

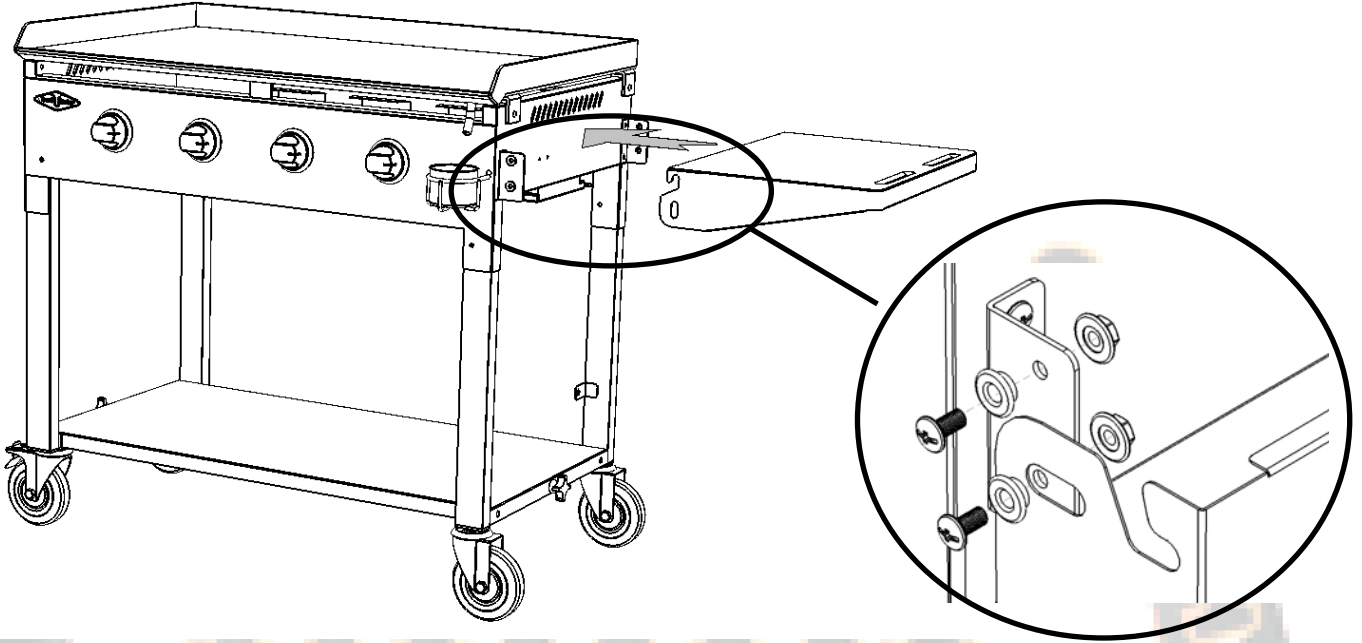

5. Install cylinder hook over the 2 studs under the right-hand side shelf.

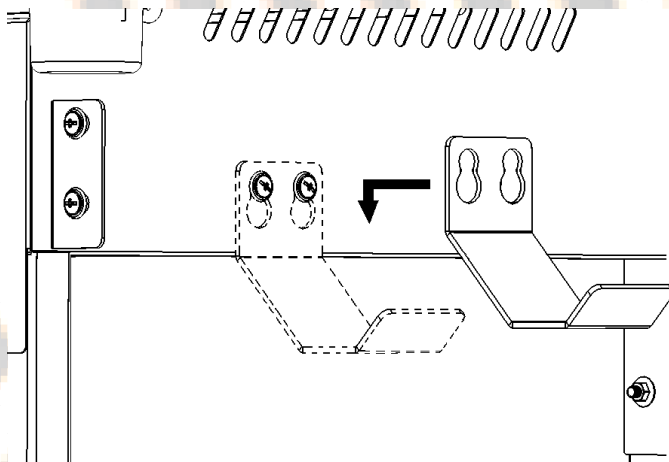

6. Fit the handle on left hand side:

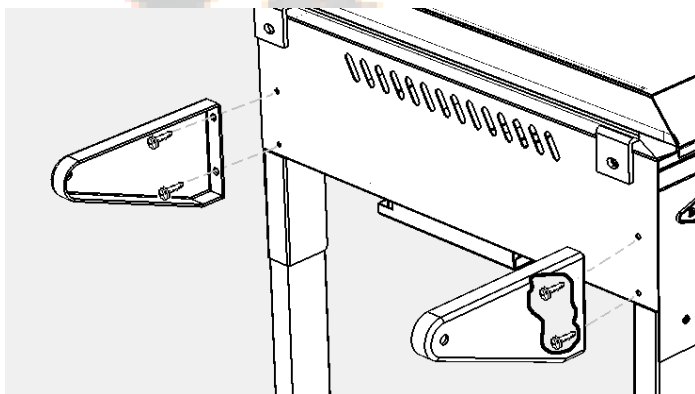

Attach the Brackets
to the BBQ body.

a.



Serious Barbecues

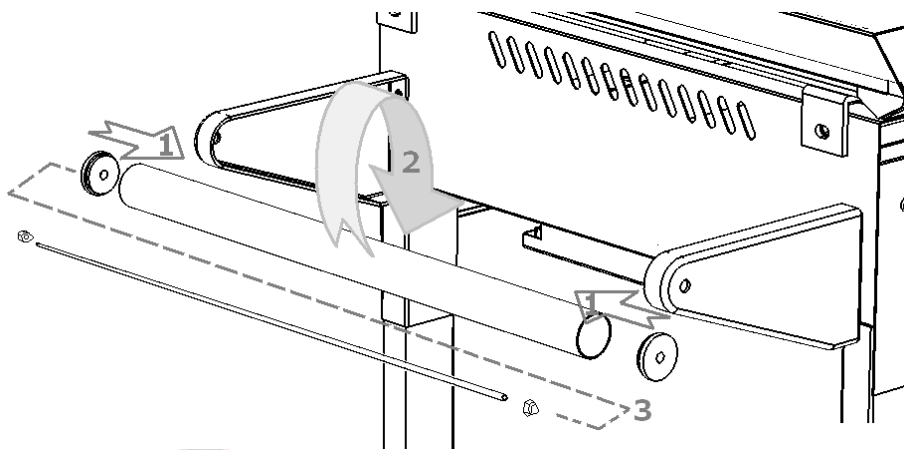

1. Assemble the black spacers to the ends of the handle tube.
2. Insert the assembled tube in between the brackets.
3. Insert threaded rod through brackets and handle, and tighten with a nut on each side.

b.

The Cooking Plate of this BBQ is designed so it can be removed for easier transportation of the appliance.

To remove the plate, you must undo the 5 thumb screws holding it to the body. Two at each side, and one at rear.

 **Note: when operating the BBQ, it must be ensured that all 5 Thumbscrews holding the plate are in place and fastened tightly.**





Connect the Regulator to the gas Cylinder

 **Verify 'Gas Type' label & data plate attached to side of barbecue is correct for the gas you are about to connect to.**

The hose and regulator is connected to the BBQ and leak tested at factory, you will only need to connect to the cylinder, as explained on page 4.

1. Make sure burner valves are in the 'Off' position.
2. Screw regulator side to the cylinder, and hand-tighten.

 **Note:** if moving the BBQ from one place to another, never drag the cylinder behind. Disconnect the cylinder first, move, and re-connect once reached the new location.

 **Note:** For storage and cylinder exchange, disconnect hose at the cylinder only, do not disconnect hose from the appliance.

Once finished using the Barbecue

1. Disassembly operation must be done after the barbecue has totally cooled off.
2. Be careful when removing fat collecting cup, because the grease in the cup may take longer to cool down.
3. When transporting the barbecue, make sure that all parts are locked firmly to place.



Serious Barbecues



Note: for 16440 and 16540 Barbecues, the plate is made of Mild Steel, and coated with non-toxic paint to protect it from rusting. With use, the coating may come off, and while posing no hazard, it is recommended to keep the plate lightly oiled while not in use, and keep the Barbecue covered, to prevent corrosion of the plate.

Using Your Barbecue:

Ignition:

Model **16440** (Stainless Steel) does not require a battery and has a QuartzStart ignition system built into every valve.

For **16540** and **16640** models, A battery must be inserted into the ignition module in order for it to work.

Unscrew the top of the ignition button (holding onto the knurled, rigid part), and insert 1 x AA battery, such that the positive (+) side is towards you. Replace cup.

Preparing the Plate:

To protect the steel cooking surface during transport and prior to purchase, a non-permanent and non-toxic coating is applied. This coating will wear off in time with use. To help preserve the cooking surfaces and to minimise corrosion and sticking, cooking plate is best seasoned before use.

Wash the plate thoroughly with mild dishwashing liquid and dry immediately. Do not allow to drain-dry. Coat top surface with a generous layer of solid vegetable oil. Do not use salted fats such as butter or margarine.

With barbecue plate placed in the correct position, light the burners according to this instruction manual. Turn the burners on to the High setting until a medium heat is attained. After about 10 minutes turn all burners Off and allow the unit to cool completely. Coat again with vegetable oil. The cooking plate is now seasoned and ready to use. The cooking surface should be frequently seasoned as above to prevent corrosion. If rust does occur, clean with a wire brush and repeat the seasoning process. In a marine environment more frequent seasoning may be required.

To Turn Off a Burner

Push in and hold the control knob while turning in a clockwise direction until the 'Off' position is reached. Failure to follow these shutdown/turnoff procedures exactly could lead to a hazardous situation.

Cooking Method

Commonly used for traditional barbecuing:

Place food over the lit plate section. Observe cooking process and turn food over as required to achieve uniform cooking.

The direct cooking method is recommended for steaks, chops, sausages, and hamburgers, as well as vegetables.



Serious Barbecues

To Operate

- A. The appliance is placed on a flat, level, non-combustible surface.
- B. Ensure the regulator is connected to the LPG cylinder (See Regulator Connection page 4.), and the hose is not subject to any twisting.
- C. Verify all joints are spanner tight and check for leaks after turning on gas supply. See correct procedure on page 4.
- D. Ensure all knobs are in the 'Off' position.
- E. Ensure cooking plate is in place, and secured with all Thumb screws.
- F. Open Gas Cylinder valve.
- G. Light each burner by following this procedure (**16540, 16640**):
 - Read all instructions before lighting.
 - Before lighting ensure plate is secured.
 - Push in and turn Left-Hand-Side knob counter clockwise to 'High', while pressing the Ignition button (a 'Clicking' sound will be heard).
 - If ignition does not occur, return to 'Off' and repeat after 5 minutes.
- H. Once the left-hand-side burner is alight, light each successive burner from left to right.
or
- I. Light each burner by following this procedure (**16440**):
 - Read all instructions before lighting.
 - Before lighting ensure plate is secured.
 - Push in and turn any knob counter-clockwise towards ⚡ 'High'.
 - If ignition does not occur, return to 'Off' and repeat after 5 minutes.
- J. Check for a clear blue flame with just a tip of yellow.

 Excess yellow tipping means the combustion is not right, if that is observed, turn the Barbecue burners off, and refer to troubleshooting at the end of this manual.

Controlling the Burners

The control knob can now be turned to the desired heat setting, Low, Medium or High. The control knob does not need to be pushed in while selecting the heat setting.

After Use

It is a good idea to leave the barbecue 'On' for about 10 minutes after you have finished cooking. This helps to burn away any excess food residues and oil, and makes cleaning easier.

- ❖ Be sure to turn off all control knobs and the gas supply.
- ❖ Allow the barbecue to cool.
- ❖ Clean the fat collecting cup and cooking surfaces. Clean any food spills from the side shelves, if they are installed.
- ❖ The gas cylinder supply valve must be turned off when the appliance is not in use.

Storing Your Barbecue

When storing barbecue for extended periods, be certain all controls and cylinder valves are turned off. If storing the barbecue indoors remove gas cylinder and store the cylinder in a ventilated area outdoors. Gas cylinders must be stored outdoors, out of reach of children and must not be stored in a building, garage or any other enclosed area. The barbecue should be covered when not in use. Eg with a polyester or vinyl barbecue cover.

Partial Enclosures

This appliance shall only be operated in an above ground, open air situation with natural ventilation, without stagnant areas, where gas leakage and products of combustion are rapidly dispersed by wind and natural convection. Any enclosure in which the appliance is used shall comply with one of the following:

Within a partial enclosure that includes an overhead cover and no more than two walls.

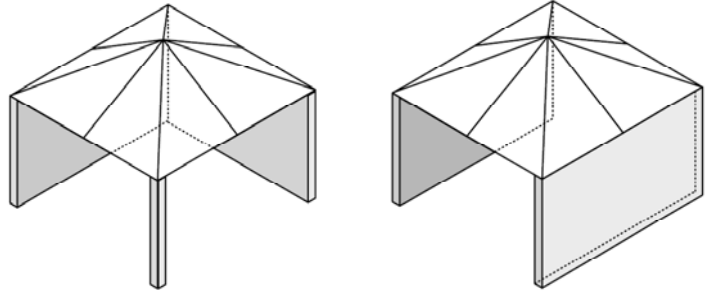

Any enclosure with walls on all sides, but at least one permanent opening at ground level, and no overhead cover.

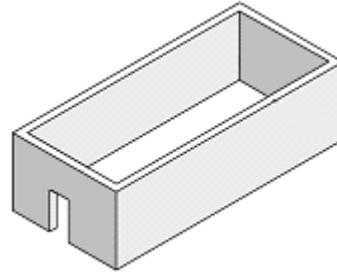

Within a partial enclosure that includes an overhead cover and more than two walls, the following shall apply:

- At least 25% of the total wall area is completely open; and
- At least 30% of the remaining wall area is open and unrestricted.

In the case of balconies, at least 20% of the total of the side, back and front wall areas shall be and remain open and unrestricted.

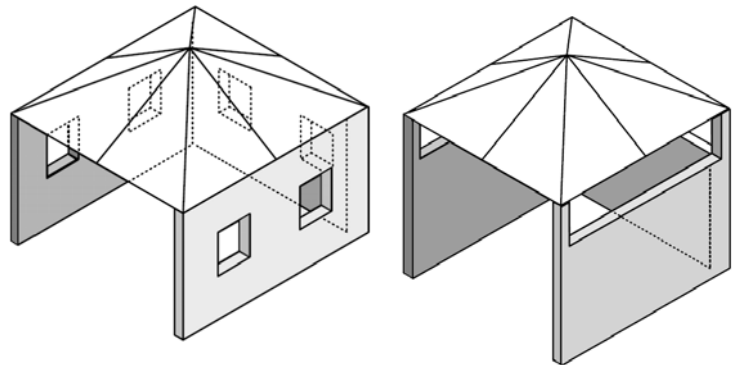

Technical Information



Note: Do not modify this appliance. Any deviation from factory settings could result in a safety hazard.

Barbecue manifold inlet thread is 3/8 SAE male flare fitting.
 Operation Gas Pressure: LPG – 2.75 Kpa; NG – 1.0 Kpa
 Energy Input: 18Mj per Burner.
 Gas Nozzle orifice size: LPG – Ø1.2mm; NG – Ø1.95mm

Appliance	LENGTH [mm]	HEIGHT [mm]	DEPTH [mm]	WEIGHT [Kg]
4 Burner ClubMan 16440, 16540, 16640	920	830	520	67



Serious Barbecues

Maintenance

1. Use only soft cloth or sponge to clean the surfaces of barbecue and then carefully dry.
2. Avoid leaving acidic or alkaline substances on the plate. It may cause discolouration and corrosion.
3. Keep the igniters probes clean. Wipe away any apparent water or dirt.
4. Clean the unit after each use to maintain the appearance and prolong the appliance's life. Do not use corrosive materials or harsh detergents to clean the BBQ.

Recommended maintenance frequency:

Service and Maintenance Schedules	Each Use	6 Monthly	2 Yearly
Check gas supply hose(s) for cracks and leaks	✓		
Check gas regulator for leaks	✓		
Check that all gas fittings are tight	✓		
Inspect and clean ignition module and probe		✓	
Inspect and clean barbecue Burners		✓	
Inspect and clean gas injectors			✓
Check gas control valve on cylinder			✓
Inspect gas control valves			✓
Inspect and proof all internal structure barbecue and trolley			✓

Service Assistance:

To assist you when contacting your after-sales service agent and to arrange for service, please complete the following details and have them ready when you call. You do not need to register your warranty. However, you must retain your receipt or proof of purchase. When claiming warranty for this appliance you must provide a copy of your proof of purchase receipt. No claims for warranty will be accepted without proof of purchase. Service and parts can be obtained at your nearest BeefEater dealer.

Model number: _____

Serial number: _____
(Can be found on Data Plate or first page of this booklet)

Retailer purchased from: _____

Date of purchase: _____



Serious Barbecues

Troubleshooting

Condition	Possible Cause	Solution
Flame goes out while in use	Empty Gas cylinder.	Replace cylinder.
	Air mixed in hoses.	Re-ignite and allow operating for a short while, till clears out
	Blockage	Seek professional assistance.
Ignition failure	gas cylinder valve close	Turn off knob button, then open the cylinder valve
	Air mixed in the hoses	Re-ignite and allow operating for a short while, till clears out.
	Rubber hose wrapped, deformed or pinched	Release hose, ensure not damaged or leaking
	Spark Escaping	Ensure the spark probe is in place, not deformed, clean.
	No Spark	Replace igniter battery Check ignition probe.
Foul smell of gas	Damage to hose	Turn cylinder valve off, replace hose.
	Leakage	Leak-test, and tighten where required. If leakage can't be rectified, cease using appliance, and seek professional assistance
	Burner went off	Shut off valves, wait for 5 minutes and reignite
	Incorrect combustion	Seek professional assistance
Flame appear to separate off the burner or flame burns with noise	blockage of burner Ports	Clean the burner thoroughly. If problem persists, Seek professional assistance



Serious Barbecues

Warranty:

Our goods come with guarantees that cannot be excluded under the Australian Consumer Law. You are entitled to a replacement or refund for a major failure and for compensation for any other reasonably foreseeable loss or damage. You are also entitled to have the goods repaired or replaced if the goods fail to be of acceptable quality and the failure does not amount to a major failure.

Should any part fail due to defective workmanship or faulty materials within the specified period from the date of purchase, BeefEater or its distributor will repair or, (at distributors option), replace the defective part free of charge.

LP / Propane Gas Cylinder

The cylinder manufacturer is responsible for the materials, workmanship and performance of the gas cylinder. Contact your dealer or the cylinder manufacturer in respect of all warranty claims or service.

Warranty Administration

In Australia, warranty is administered by BeefEater Barbecues.

To ensure speedy processing of your warranty service claim, ensure that you record all specific details about your appliance in the space provided. Keep this information handy for future reference, and a copy of your purchase receipt.

NOT COVERED

Storage

Exposure of the barbecue appliance to the elements should be minimised. Once the unit has cooled and is cleaned, store the barbecue under cover. Metal covers are an optional accessory that will ensure years of trouble free operation.

This warranty does not cover the purchaser or any other person for damage, malfunction or loss due to the following:

- Lack of maintenance, abuse, neglect, misuse, accident or improper installation of this appliance.
- Scratches, dents, corrosion or discolouring caused by heat, abrasive or chemical cleaners or chipping of porcelain or painted parts.
- Corrosion or damage caused by exposure to the elements, grease fires, insects, weather or hail.
- Cleaning and normal wear and tear. Service calls of this nature are chargeable.
- Rusting of steel plates and burners.
- Commercial use of the barbecue.
- Unauthorised repairs during the warranty period
- Removal or re-installation costs.
- Cracks and weathering of plastic parts caused by exposure to the elements or damage by weather, heat, insects, chemicals or foods acids or juices.

Note: Barbecues must be covered when not in use.

Note: Rust should be removed by a scrub pad and the surface coated with cooking oil. See owners manual – Caring for cooking surfaces. Cooking surfaces must be covered when not in use.

Conditions of Warranty

1. The appliance is delivered to the BeefEater distributor's service department or authorised service agent and freight charges both ways are paid by the owner. No liability is accepted for loss or damage during transit.
2. The appliance is operated and maintained in accordance with the instructions supplied.
3. Repairs or service must be carried out by an authorised person. Installation must conform to the applicable Gas, Electrical and Building standards laid down by the local codes for your state or region.
4. No alterations or repairs have been carried out without obtaining the distributors prior consent. Such repair or any replacement does not extend the warranty period.
5. Proof of purchase together with this warranty card must be provided to verify purchase date and establish the warranty period. Only the original purchaser is covered under this warranty.
6. The warranty period is calculated from the date of purchase only.
7. Where this warranty is inconsistent with any state laws, the statutory rights of the purchaser shall prevail.
8. Parts installed from other manufacturers' products will void this warranty.

Warranty Term

All parts and workmanship of this appliance are covered for a period of 1 year from date of purchase.



Beef Eater
Serious Barbecues

Spare Parts:

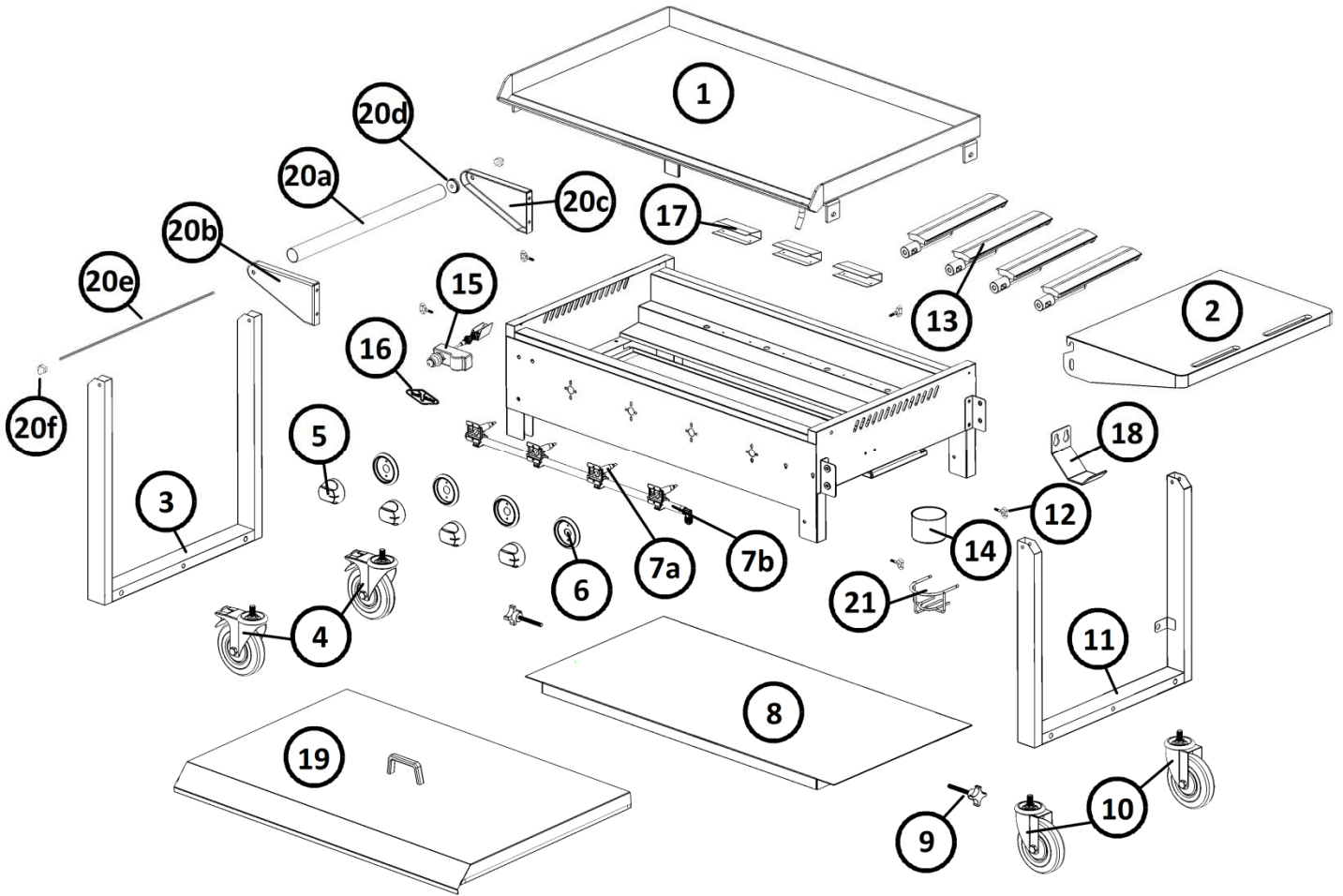

Index		Description	Qty	Part Number	
				16540	16640
1	Cooking Plate	1	476001	476001SS	476001
2	Shelf	1 or 2	476002	476002	476002
3	LH Side Leg Assembly	1	476003	476003SS	476003a
4	Clubman Castor with Brake	2	476004	476004	476004
5	Knob	4	060542	060543	060544
6	Dress Ring - Chrome	4	060552	060553	060554
7a	Gas Valve	4	040230	040231	040230
7b	Manifold	1	476007	476007	476007
8	Bottom Shel / Brace	1	476008	476008SS	476008a
9	Hand Screw	2	476009	476009	476009
10	Clubman Castor	2	476010	476010	476010
11	RH Side Leg Assembly	1	476011	476011SS	476011a
12	Thumb Screw	5	476012	476012	476012
13	Burner	4	94701	94701	94701
14	Fat Collecting Cup	1	476014	476014	476014
15	Ignition Module	1	476015	--	476015
16	BeefEater Badge	1	060509	060509	060509
17	Cross-Fire Channel	3	476017	476017	476017
18	Cylinder Hook	1	476018	476018SS	476018
19	Weather Lid with Handle	1	476019	476019	476019
20a	Handle Bar	1	--	476020a	476020a
20b	Front Handle Bracket	1	--	476020b	476020b
20c	Rear Handle Bracket	1	--	476020c	476020c
20d	Handle Spacer	2	--	476020d	476020d
20e	Threaded Rod	1	--	476020e	476020e
20f	Dome Nut	2	--	476020f	476020f
21	Fat Collecting Cup Holder	1	476021	476021	476021



Serious Barbecues

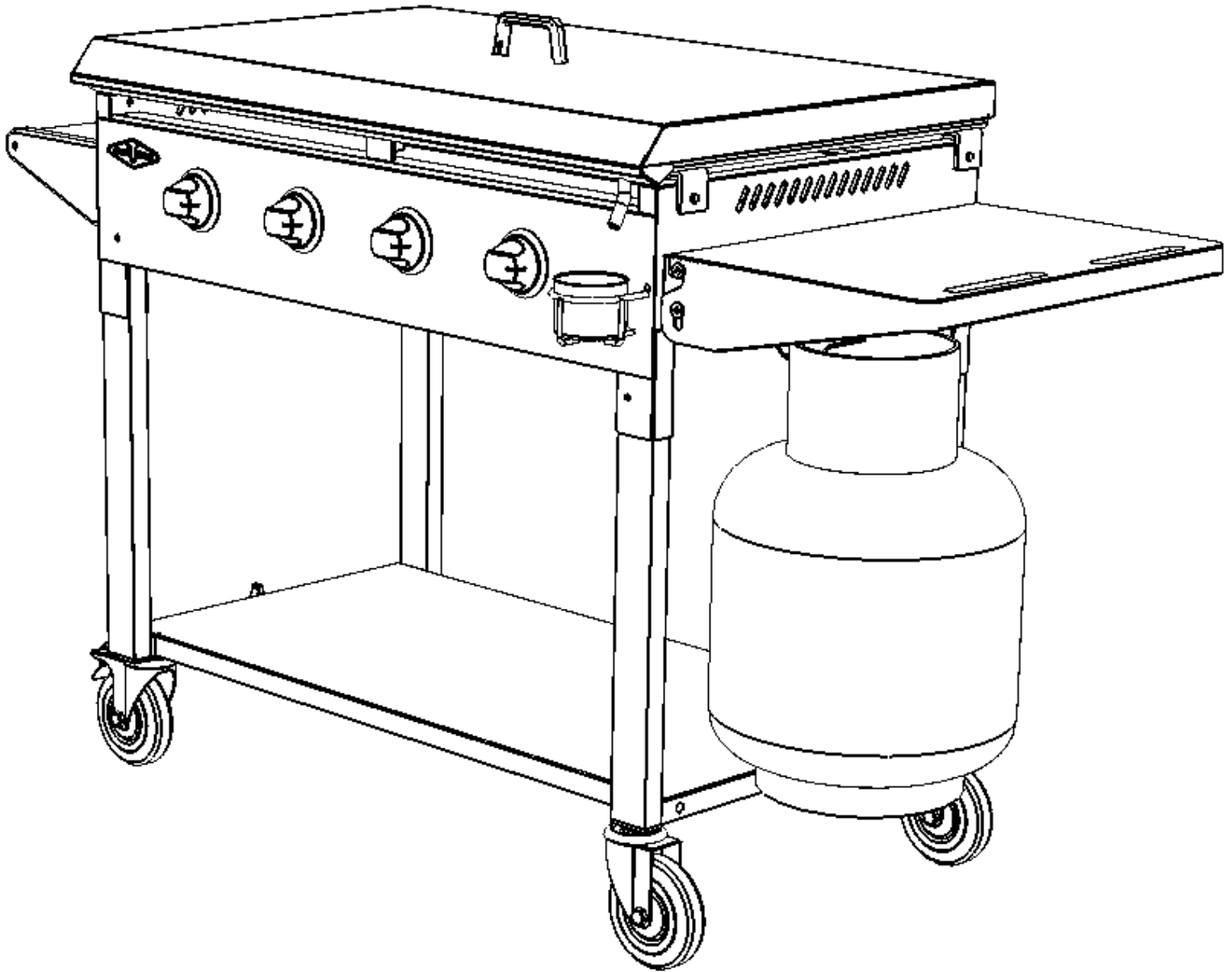

Woodland Home Products

3-5 Birmingham Av, Chester Hill,
NSW, Australia, 2162

Phone: 1800 356 660

Facsimile: 02 9724 8899

E-mail: mail@beefeaterbbq.com

Website: www.beefeaterbbq.com