

# USER INSTRUCTIONS

## STRATOS 3 BURNER

MODEL No's 9873I, 98733

## STRATOS 4 BURNER

MODEL No's 9874I, 98743



CE



LIVE THE BRAAI LIFE

**CAUTION**

For Outdoor use only!

This appliance may not be used in an exterior enclosed balcony, porch or entertainment area!

**IMPORTANT**

Read these instructions for use carefully so as to familiarize yourself with the appliance before connecting it to its gas container. Keep these instructions for future reference

**1. Introduction**

- This appliance complies with BS EN 498: 2012 and SANS 1539:2012
- This appliance must only be used with an approved hose and regulator.
- The gas cylinder is to be used only in the upright position.
- Only to be used with a gas cylinder that does not exceed 500 mm in height and 350mm in width (Including the regulator)
- Gas appliances require ventilation for efficient performance and to ensure the safety of users and other persons in close proximity.
- **Use outdoors only!**
- **Warning:** Accessible parts may be very hot. Keep young children away
- When using a pot, the minimum recommended pot size is 150 mm and maximum recommended pot size is 300mm.

98731, 98733, 98741, 98743					
Country of Use	BE, CH, CY, CZ, ES, FR, GB, GR, IE, IT, LT, LU, LV, PT, SK & SI		PL	BE, CY, DK, EE, FR, FI, HU, IT, LT, NL, NO, SE, SI, SK, RO, HR, TR, BG, IS, LU, MT, & ZA	AT, CH, DE & SK
Appliance Categories	I <sub>3</sub> (28-30/37)		I <sub>3B/P</sub> (37)	I <sub>3B/P</sub> (30)	I <sub>3B/P</sub> (50)
Allowable gasses	Butane	Propane	Butane, Propane or their mixture		
Gas Pressure	28-30mBar	37mBar	37mBar	28-30mBar (2.8kPa for South Africa)	50mBar
Main BBQ Unit - 3 Burner (98731, 98733)					
Jet Number	0.92			0.81	
Nominal Usage (Butane)	255g/hr per burner	277g/hr per burner	255g/hr per burner	255g/hr per burner	
Gross nom. heat input	3.5kw Per Burner (3.5kW x 3 = 10.5kW)	3.8kw Per Burner (3.8kW x 3 = 11.4kW)	3.5kw Per Burner (3.5kW x 3 = 10.5kW)	3.5kw Per Burner (3.5kW x 3 = 10.5kW)	
Main BBQ Unit - 4 Burner (98741, 98743)					
Jet Number	0.92			0.81	
Nominal Usage (Butane)	255g/hr per burner	277g/hr per burner	255g/hr per burner	255g/hr per burner	
Gross nom. heat input	3.5kw Per Burner (3.5kW x 4 = 14kW)	3.8kw Per Burner (3.8kW x 4 = 15.2kW)	3.5kw Per Burner (3.5kW x 4 = 14kW)	3.5kw Per Burner (3.5kW x 4 = 14kW)	
Side Burner (98733, 98743)					
Jet Number	0.88			0.75	
Nominal Usage (Butane)	218g/hr	255g/hr	218g/hr	218g/hr	
Gross nom. heat input	3.0kW	3.5kW	3.0kW	3.0kW	
Gas Supply Sources	An approved hose and regulator connected to a refillable gas container not exceeding 9kg and complying with local regulation in force				

Country Name and Abbreviations				
AE = United Arab Emirates	AL = Albania	AT = Austria	BE = Belgium	CH = Switzerland
CZ = Czech Republic	DE = Germany	DK = Denmark	ES = Spain	FI = Finland
FR = France	GB = United Kingdom	GR = Greece	HR = Croatia	IT = Italy
JP = Japan	KR = Korea	NL = Netherlands	NO = Norway	PL = Poland
PT = Portugal	RO = Romania	RU = Russia	RS = Serbia	SI = Slovenia
SK = Slovakia	SE = Sweden	TR = Turkey		

For gas category I3B/P(30); I3+(28-30/37) &amp; I3B/P(50):

Stratos 3 with side burner, model 98733, Total heat input: 13.5KW / Butane 983g/hour  
 Stratos 3 with side tables, model 98731, Total heat input: 10.5KW / Butane 765g/hour  
 Stratos 4 with side burner, model 98743, Total heat input: 17KW / Butane 1238g/hour  
 Stratos 4 with side tables, model 98741, Total heat input: 14KW / Butane 1020g/hour

For gas category I3B/P(37):

Stratos 3 with side burner, model 98733, Total heat input: 14.9KW / Butane 1086g/hour  
 Stratos 3 with side tables, model 98731, Total heat input: 11.4KW / Butane 831g/hour  
 Stratos 4 with side burner, model 98743, Total heat input: 18.7KW / Butane 1363g/hour  
 Stratos 4 with side tables, model 98741, Total heat input: 15.2KW / Butane 1108g/hour

## 2. Safety Information

- The hose and seal on the regulator must be checked for wear or damage before every use and before connecting to the gas cylinder (see Fig. 1).
- Ensure the appliance is used away from flammable materials. Minimum safe distances are 1.2m above the appliance and 600mm to the rear and sides of the appliance (see Fig. 2).
- Do not use an appliance that is damaged, leaking, or which does not operate properly.
- Keep gas cylinders away from heat and flames. Do not place on a stove or any other hot surface.
- Ensure that the assembled unit is stable and does not rock.
- Do not cover or change the primary air supply openings in the burners as this will affect the performance of the product and may lead to an unstable flame.
- In the event of burn back, (where the flame burns back and ignites at the jet), immediately turn off the gas supply by first closing the control valve on the gas cylinder and then the appliance valve. After the flame is extinguished remove the regulator and check the condition of its seal. Replace the seal if in doubt. Re-light the appliance as described in Section 3 below. Should the flame light back persistently return the product to your authorized CADAC repair agent.
- If there is a leak on your appliance (smell of gas), immediately close the control knob on the gas cylinder. If you wish to check for leaks on your appliance, do it outside. Do not try to detect leaks using a flame; use soapy water.
- The correct way is to smear the joints with soapy water. If a bubble or bubbles form then there is a gas leak. Immediately turn off the gas supply firstly by closing the control valve on the gas container and then the appliance valve. Check that all the connections are properly fitted. Re-check with soapy water. If a gas leak persists, return the product to your CADAC dealer for inspection / repair.
- Do not modify the appliance or use it for anything which it has not been designed for.
- During use, part of the appliance will become hot, particularly the cooking areas and the hood. Avoid touching hot parts with your bare hands. The use of oven gloves is recommended.
- Keep young children away from the appliance at all times.
- This appliance consumes oxygen and needs ventilation for optimum performance and for the safety of those in close proximity. **Use Outdoors Only!**
- Do not move the appliance while in use.
- The parts sealed by the manufacturer or its agent must not be altered by the user.

### NOTE

- Do not twist or pinch the hose. Ensure that it is kept away from the BBQ body so as to prevent deterioration/damage to the hose caused by heat.
- Fit one end of the low pressure hose onto the regulator nozzle. Thread the other end from inside cabinet, through the hole on the left side panel, onto the Patio BBQ nozzle. Push the ends on as firmly as possible. Clamp them into position using hose clamps at both ends of the hose.
- Ensure that the connections are made securely and do not allow gas to leak.
- Check for gas leaks before using the appliance.
- For use with an approved hose and regulator connected to a refillable gas container not exceeding 9kg and complying with local regulation in force.
- Do not obstruct the ventilation openings of the cabinet.
- Do not modify the appliance. Modifying the appliance may be dangerous.
- **Warning:** An LP cylinder not connected for use shall not be stored in the vicinity of this or any other appliance.

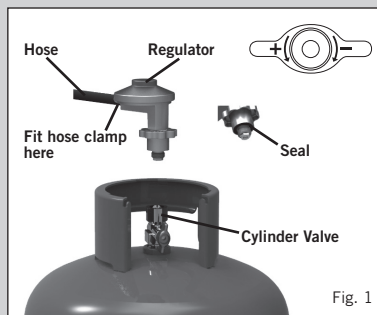

Fig. 1

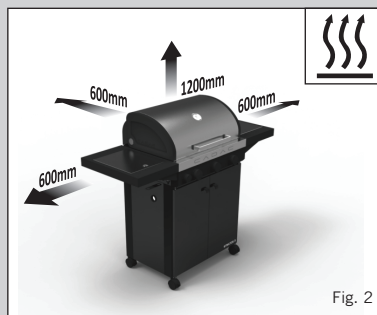

Fig. 2

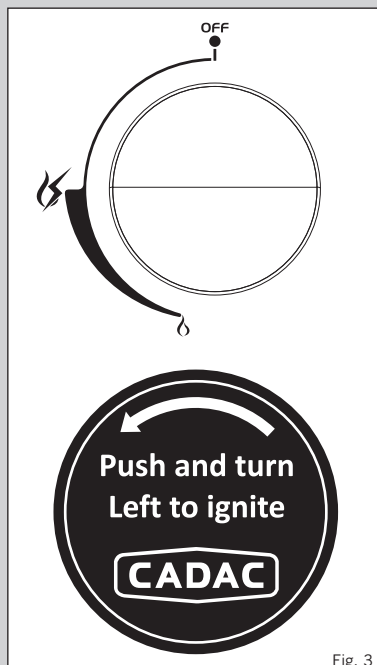

Fig. 3

### 3. Using the Appliance

- Place the cylinder inside the cabinet through the back of the cabinet into the allocated space.
- Use this appliance only on a firm level surface.
- Before use ensure that the drip cup is in place.
- Make sure the gas cylinder is correctly fitted to the appliance.
- Ensure the cylinder control valve is in the open position.
- **Note!** All burners are fitted with an automatic igniter.  
To light the appliance using the automatic igniter, first ensure the dome is in the open position. Push in and turn the control knob in an anti-clockwise direction until spring resistance is felt. Hold the knob in this position for 3 – 5 seconds to allow the gas to flow and then turn the knob fully anti-clockwise to the HIGH position. This will cause the automatic lighter to light the burner. Should the burner not ignite the first time, turn the control knob to the OFF position and wait 5 minutes, repeat the process until the burner ignites.
- **Manual ignition:** To light the burners manually, first remove the grill plate and the deflector plate directly underneath it. Ignite a match or firelighter and position it next to the left hand burner. Turn on the gas supply to that burner only by pushing the control valve in and turning it in an anti-clockwise direction. This will ignite the burner. Once the burner is ignited, carefully replace the deflector plate and cast iron grill plate. You will now be able to light the remainder of the burners as above.
- Use the control knobs to adjust the individual burner flame intensity to the desired level by turning the knob anti-clockwise to decrease the flame and clockwise to increase it (see Fig. 3).
- After use, first close the valve on the gas cylinder. When the flame is extinguished, close the burner control valves on the appliance by turning control knobs fully clockwise.

### 4. Fitting and Changing the Gas Cylinder

- Before connecting the appliance to a gas cylinder, ensure that the rubber seal on the regulator is in position and in good condition.
- Carry out this check each time you fit the appliance to a gas cylinder (see fig. 1).
- Blow out any dust from the cylinder opening to prevent possible blockage of the jet.
- Ensure the gas cylinder is fitted or changed outdoors, away from any source of ignition such as naked flames, and away from other people.
- Make sure that the gas cylinder is kept upright at all times. Hand tighten the regulator onto the cylinder until it is fully engaged.
- If there is a leak on your appliance (smell of gas), extinguish all sources of ignition in the vicinity of the appliance. If you wish to check for leaks on your appliance, use soapy water which is applied to the suspected area. A formation of bubbles will indicate a gas leak. Check that all the connections are securely fitted and re-check with soapy water. If you cannot rectify the gas leak, do not use the appliance. Contact your local CADAC stockist for assistance.
- When changing a gas cylinder, first close the cylinder valve and then the appliance valve, making sure the flame is extinguished and unscrew the regulator. Re-fit the regulator to a full cylinder following the same precautions as described above.
- After the appliance has been fully assembled, perform a gas leak test before operating the appliance.

### 5. General Maintenance

- There are no predetermined maintenance intervals for this appliance.
- It is dangerous to use an appliance with a cracked or perished seal and/or hose. Inspect both seals and hose regularly and replace if they are not in order before using the appliance.
- If the appliance was in use it will be hot. Allow to cool sufficiently before attempting any maintenance.
- CADAC Patio BBQ's are fitted with specific CADAC jets to regulate the correct amount of gas. Should the hole in the Jet become blocked it may result in a small flame or no flame at all. Do not attempt to clean the Jet with a pin or other such device as this may damage the hole, which could make the appliance unsafe. Refer to "**Introduction**" (Section 1) for jet sizes.

#### 5.1.Replacing a Blocked Jet

- Ensure that the cylinder valve is closed, then disconnect the appliance from the gas cylinder.
- Remove the grill plates. Remove the flame tamers to expose the burners. Remove the retaining screws of the affected burner.
- Remove the affected burner by lifting it out of its location taking care not to damage the control valve whilst doing so. This will expose the Jet.
- Unscrew the blocked Jet with a suitable spanner and replace it with a new Jet. Do not use pliers on the Jet as they can cause damage, making the Jet unusable or impossible to remove.
- To re-assemble, reverse the above procedure. Do not over tighten as this may damage the Jet.

#### 5.2.Replacement of Hose

- The hose length should not be less than 0.8m or exceed 1.2m. Check the expiry date on the hose and replace when necessary. Fitting of a hose is described in Section 2. Only an LPG hose that complies with SANS 1156-2, BS 3212 or DIN4815 may be used with this appliance.

## 5. General Maintenance cont.

### 5.3.Replacement of Regulator

- In South Africa the regulator used must be 2.8kpa and it must comply with SANS 1237.
- Use 30mBar butane (or propane) regulator with gas category I3B/P(30)
- Use 30mBar butane regulator with gas category I3+(28-30/37) for butane.
- Use 37mbar butane(or propane) regulator with gas category I3B/P(37)
- Use 37mbar propane regulator with gas category I3+(28-30/37)
- Use 50mBar butane (or propane) regulator with gas category I3B/P(50)
- It is important that the connection between the regulator outlet and the low pressure hose is tight and that it is secured with a metal hose clamp. Always check the joint for gas leaks as described in section 4 above.

## 6. Troubleshooting

- A normal flame is blue and may have an orange or yellow tip. If the flame is completely yellow, it may be that the jet is not securely fitted. Re-tighten the jet to ensure there is no gas leakage. An overfilled gas cylinder can also cause large yellow flames. If this is the case the cylinder should be returned to the filling station and checked by weight.
- Check that the primary air supply holes in the burners are clear and free of obstructions.
- If the flame power drops or the gas will not light, check that the gas cylinder still contains gas (shake to hear the noise made by a liquid). If there is still gas, the jet might be blocked or partially blocked.
- If you suspect a blocked jet, follow the instructions above to clean or replace it.

## 7. Cleaning

- To clean the body, simply wipe with a damp cloth using a little detergent if necessary.
- Do not use abrasive cleaners or scourers as this will cause permanent damage to the painted surface.
- Even though stainless steel is remarkably resistant to tarnish and rust relative to ordinary steels, it still requires proper care. We recommend the following:
- After use, clean the stainless steel surfaces with clean water and a soft cloth for light cleaning, while a commercially available stainless steel cleaner with a soft cloth should be used for tougher areas. Ensure that you remove all excess stainless steel cleaner after cleaning your BBQ.
- To repair minor tea staining or pitting, you can use a light, non-metallic scourer. It is important that you rub with the natural grain of the stainless steel surface to avoid leaving visible scratch marks.
- Between uses, it is a good idea to leave the barbeque covered to prevent dust and air borne salts settling on the stainless steel surfaces.
- With a small amount of care, your investment in quality stainless steel will keep its beautiful finish as well as its value for a long time to come.

## 8. Storage

- Handle the appliance with care. Do not drop it.
- After use, wait until the appliance has cooled down, disconnect it from the gas cylinder and store in a cool dry place away from heat.
- Keep the dome closed when not in use to prevent dirt and insects falling into the unit, which may affect the gas flow.
- Use a CADAC BBQ cover, especially if the unit is stored outdoors.
- Before every use, ensure that the burners and venturies are free of insects, dust and spider webs.

## 9. Spares and Accessories

- Always use genuine CADAC spares as they have been designed to give optimum performance.

Description	Part No.
Jet No. 0.92 (28/37mBar) / (2.8kPa - SA Only)	0.92
Jet No. 0.81 (50mBar)	0.81
Jet NO. 0.88 (Side Burner) (28/37mBar) / (2.8kPa - SA Only)	0.88
Jet NO. 0.75 (Side Burner) (50mBar)	0.75
Stratos 3B Cover	98700-30-CVR
Stratos 4B Cover	98700-40-CVR
Stratos Warmer Pan	98700-50
Stratos Reversible Grill Plate	98700-51

## 10. Returning the Appliance for Repair or Service

- Do not modify the appliance. This may cause the appliance to become unsafe.
- Any modifications will render the CADAC (Pty) Ltd warranty null and void.
- If you cannot rectify any fault by following these instructions, contact your local CADAC stockist for inspection and/or repair.

## 11. Warranty

- CADAC (Pty) Ltd hereby warrants to the ORIGINAL PURCHASER of this CADAC Gas Barbecue, that it will be free of defects in material and workmanship from the date of purchase as follows:

<b>Valves:</b>	5 Years
<b>Plastic parts:</b>	No Warranty
<b>Enamel parts (Except Flame Tamers):</b>	5 Years
<b>Cast Iron:</b>	5 Years
<b>Painted Frames:</b>	1 Year
<b>Stainless Steel Burners:</b>	2 Years
<b>Enamel Flame Tamers:</b>	2 Years

The warranty will only apply if the unit is assembled and operated in accordance with the printed instructions.

CADAC may require reasonable proof of your date of purchase. THEREFORE, YOU SHOULD RETAIN YOUR SALES SLIP OR INVOICE.

This Limited Warranty shall be limited to the repair or replacement of parts that prove defective under normal use and service and which on examination shall indicate, to CADAC's satisfaction, they are defective. Before returning any parts, contact the customer service representative in your region using the contact information provided with your manual or call 0860 223 220 (RSA only). If CADAC confirms the defect and approves the claim, CADAC will elect to replace such parts without charge. CADAC will return parts to the purchaser, freight or postage prepaid.

This Limited Warranty does not cover any failures or operating difficulties due to accident, abuse, misuse, alteration, misapplication, vandalism, improper installation or improper maintenance or service, or failure to perform normal and routine maintenance, including but not limited to damage caused by insects within the burner tubes, as set out in this owner's manual. Deterioration or damage due to severe weather conditions such as hail, hurricanes, earthquakes or tornadoes, discoloration due to exposure to chemicals either directly or in the atmosphere, is not covered by this Limited Warranty.

There are no other express warranties except as set forth herein and any applicable implied warranties of merchantability and fitness are limited in duration to the period of coverage of this express written Limited Warranty. Some regions do not allow limitation on how long an implied warranty lasts, so this limitation may not apply to you.

CADAC is not liable for any special, indirect or consequential damages. Some regions do not allow the exclusion or limitation of incidental or consequential damages, to this limitation or exclusion may not apply to you.

CADAC does not authorize any person or company to assume for it any obligation or liability in connection with the sale, installation, use, removal, return, or replacement of its equipment; and no such representations are binding on CADAC.

This Warranty applies only to products sold at retail.

To enjoy and ensure longevity of your CADAC product, please refer to the cleaning and maintenance section of the user manual with particular attention to the care of the Stainless Steel.



**Distribuidor oficial para España:**

**The Barbecue Store**  
**Avda. Carmen Saenz de Tejada, 1**  
**29650 Mijas Costa (Málaga)**  
**Teléfono: 952477152 - 952477161**  
**Fax.: 952580781**  
**Email: dmbrico2@telefonica.net**  
**http://www.thebarbecuestore.es**