

## Product Dimensions

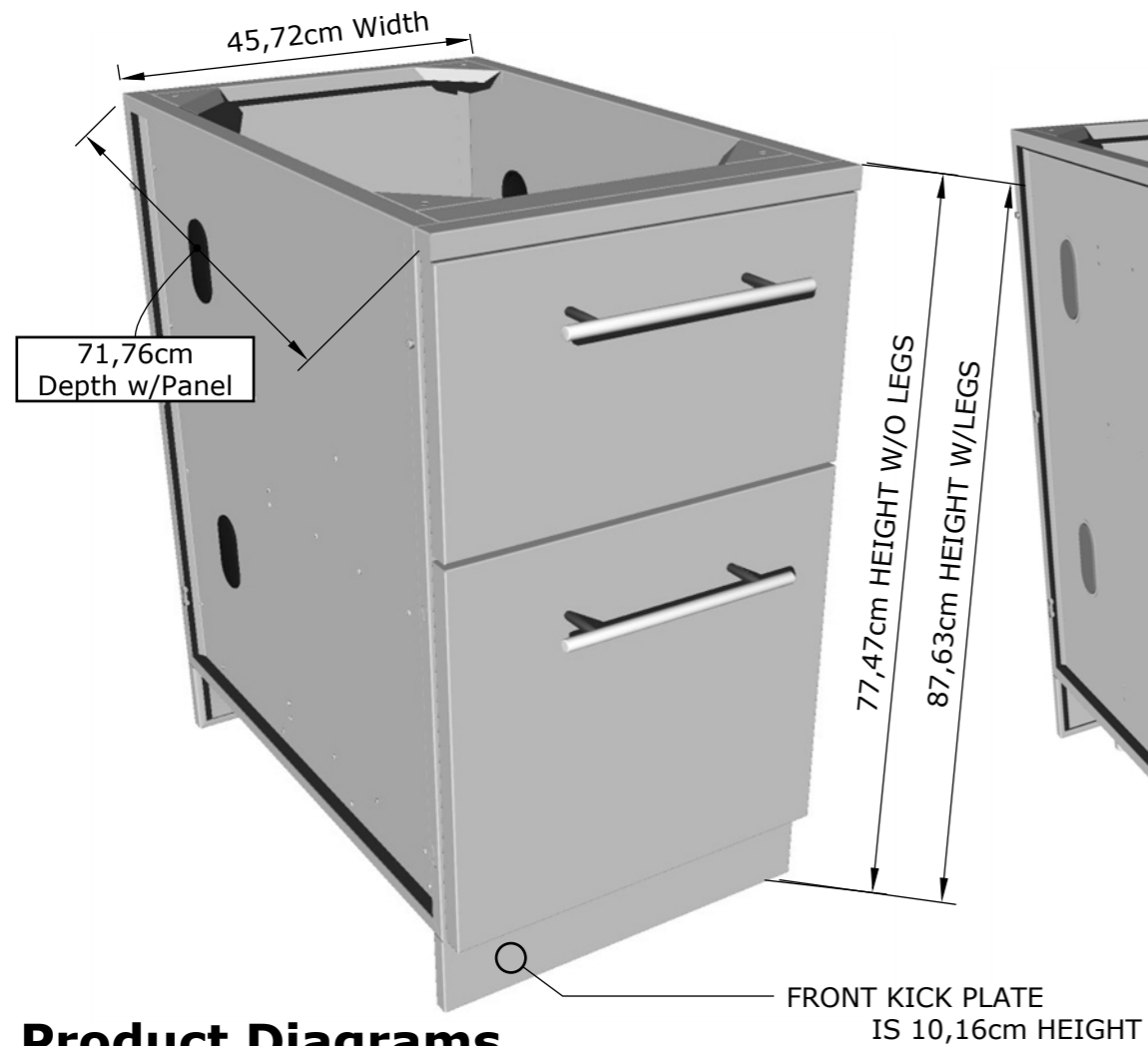

## Product Configurations

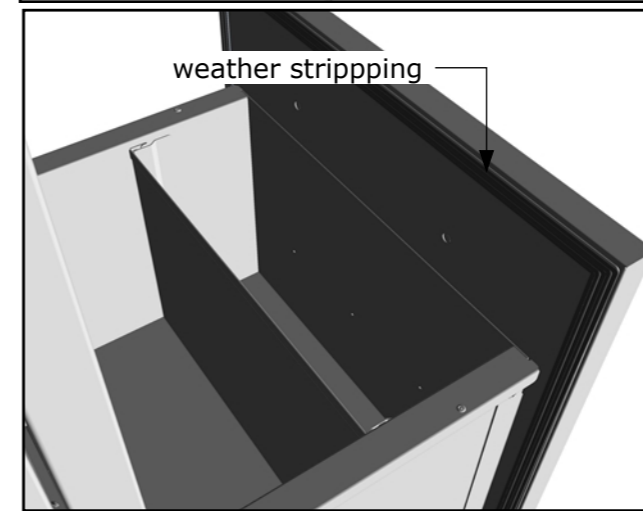
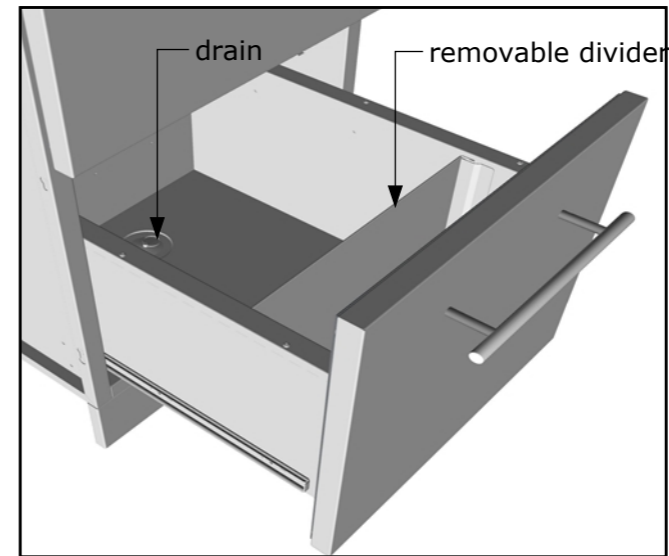

### PRODUCT

Paper Towel/Cutlery Drawer w/ Insulated Ice Chest Dry Storage Drawer

Item No. SBC18DPIC

- Lifetime Structure Warranty
- 304 Stainless Steel Structure
- Front & Back Kick-Plates
- Easy Pin-Lock Installation
- Covered Access Ports
- Adjustable Peg-Legs
- Optional Wheel Casters
- Rain Gutter on Both Drawers
- Paper Towel & Cutlery Drawer
- Weather Stripping
- Dry Storage Pantry Drawer
- Cutting Board
- Flexible Drain

### PRODUCT DIMENSIONS

45,72cm W x 71,76cm D (w/Doors) x 87,63cm H (w/Legs) or 77,47cm H (no Legs) or Upto 91,44cm Max Adjustable Height

### MATERIAL SPECS

304 Stainless Steel for the Entire Structure, 20 Gauge for Door Panel, 20 Gauge for Cabinet Panel, 304 SS Peg Legs, 304 SS Rod Handles

## Product Diagrams

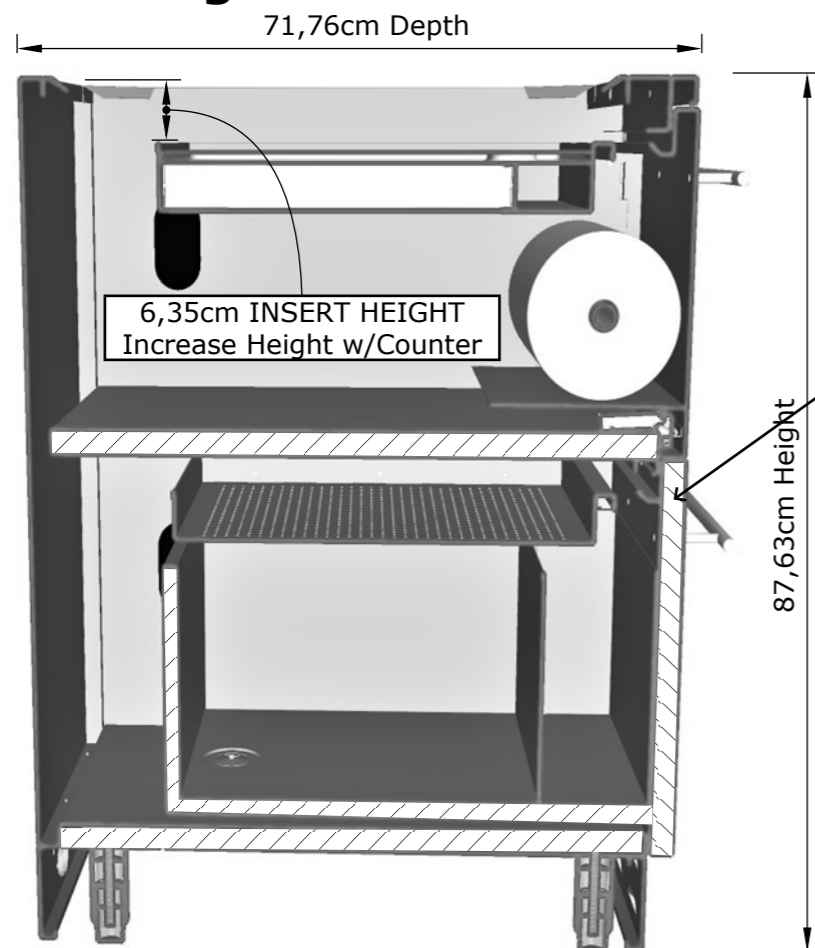

Double Walled Insulated Drawer & Lower Box

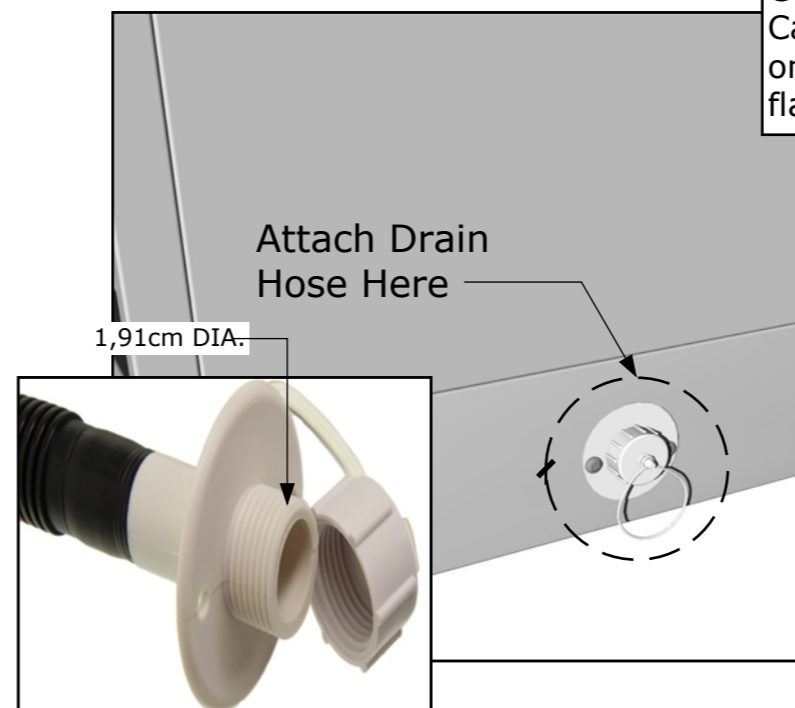

Cabinet has Bottom Drain, with Flex Hose you can attach a standard Garden Hose to outside back of Cabinet Polypropylene drain trap on one end and ABS plastic evacuation flange on the other end.



Includes 63,5cm of 1,91cm diameter hose.

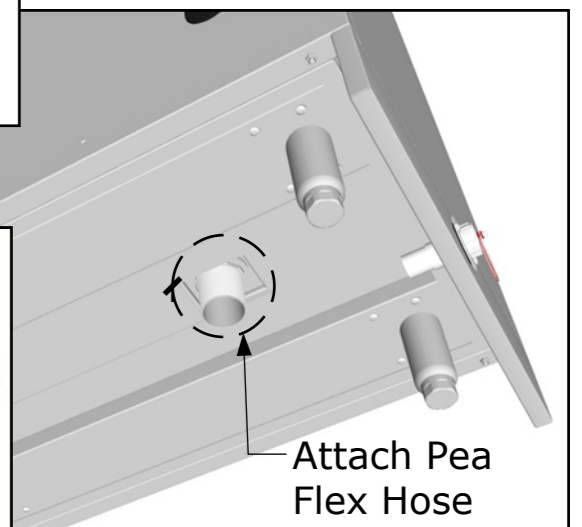

ADA COMPLIANT LEGS/KICKPLATES NOT AVAILABLE ON THIS CABINET BECAUSE OF DRAIN